

Straight Router Cutters with Insert Knives



653



D mm	I mm	L mm	S mm	Spare Knives		PACK QTY.	ORDER NO. Right-hand rotation
				side	top		
16	28,3	92	20	790.283.12	790.075.00	10	653.661.11
16	48,3	111,5	20	790.483.12	790.075.00	10	653.662.11
18	48,3	111,5	20	790.483.12	790.075.00	10	653.681.11
20	48,3	111,5	20	790.483.12	790.096.00	10	653.701.11

Spare parts

790.075.00	7,5x12x1,5mm knife
790.096.00	9,6x12x1,5mm knife
790.283.12	28,3x12x1,5mm knife
790.483.12	48,3x12x1,5mm knife
990.072.00	M3,5x3,5mm Torx screw
990.074.00	M4x3,5mm Torx screw
990.075.00	M4x6mm Torx screw
991.061.00	T15 Torx key

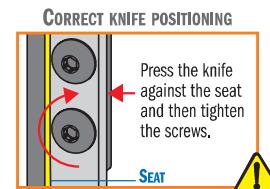

TECHNICAL DETAILS:

- Super strength steel.
- 2 cutting edges [Z1+1].

APPLICATION:

straight router bit with one replaceable plunging knife and one-sided knife fixed by special Torx screws. The body is precision balanced. For finishing and routing, plunge cutting and grooving in board materials (laminated chipboards, MDF) and hardwood. For use on CNC machining centres.

Spoilboard Surfacing Router Cutters with Insert Knives



663



D mm	I mm	L mm	S mm	PACK QTY.	ORDER NO. Right-hand rotation	Spare parts	
60	12	80	12x50	1	663.004.11	790.120.03	990.075.00
80	12	90	20x60	1	663.003.11	790.120.03	990.075.00

Spare parts

991.061.00	T15 Torx key
990.036.00	M8x25mm TE screw (only for 663.003.11)
990.020.00	Hex nut for threaded arbors M8 (only for 663.003.11)

The screw 990.036.00 and the nut 990.020.00 (on the shank) only fit item 663.003.11

TECHNICAL DETAILS:

- Super strength steel.
- 3 cutting edges [Z3].

APPLICATION:

the new router bit for CNC routers is ideal for fast removal of material over a large surface area leaving an improved finish at the bottom of the cut. Used on soft and hardwood, particle board and MDF. The cutter uses 4-sided inserts in super micrograin carbide.

A cost effective solution compared to brazed router bits and solid carbide spiral bits.

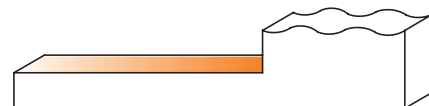
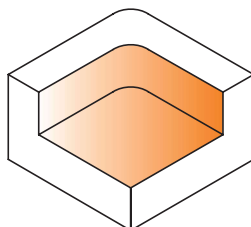

Drawings are 1:2 scale

Mini Spoilboard Surfacing Cutters with Insert Knives

new

CMT ORANGE TOOLS



663

D mm	I mm	L mm	S mm	PACK QTY.	ORDER NO. Right-hand rotation	Spare parts	
38	12	60	12x35	1	663.005.11	790.120.03	990.075.00

Spare parts 991.061.00 T15 Torx key

TECHNICAL DETAILS:
 - Super strength steel.
 - 3 cutting edges [Z3].

APPLICATION:
 the new router bit for CNC routers is ideal for fast removal of material over a large surface area leaving an improved finish at the bottom of the cut.
 Used on soft and hardwood, particle board and MDF. The cutter uses 4-sided inserts in super micrograin carbide.

A cost effective solution compared to brazed router bits and solid carbide spiral bits.

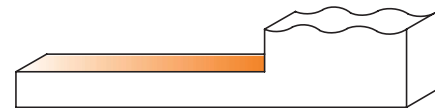
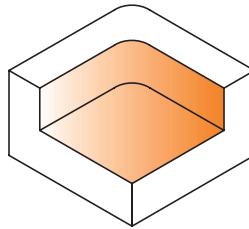

Drawings are 1:2 scale

Universal Profile Cutter for CNC Machines



663.301

D mm	I mm	L mm	S mm	PACK QTY.	ORDER NO. Right-hand rotation
65	40-50	93	20	1	663.301.11

Spare parts 692.999.01 38x15x16mm wedge for cutter
 990.068.00 M5x5mm TCEI screw
 991.064.00 Hex key 4mm

TECHNICAL DETAILS:
 - Super Strength steel.
 - 2 cutting edges [Z2]
 for knives 40x4mm and 50x4mm.

APPLICATION:
 for universal profiling of solid wood on CNC router machines. For cutting width 40mm and 50mm (serie 690). Profile knives may only be ordered and used in pairs. For router machines with mechanical feed.

USEFUL TIPS: for enhanced safety, when using 50mm knives, it is recommended to carry out the cut in several passes.

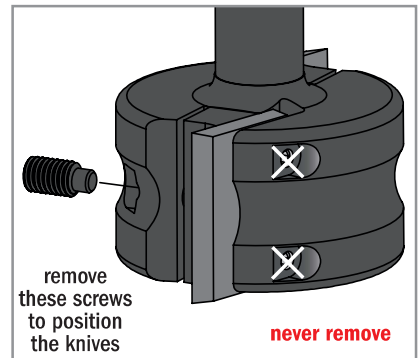

TO BE USED WITH SP KNIVES SERIES 690 (SEE PAGE 116~129)

Knives not included in cutter package.

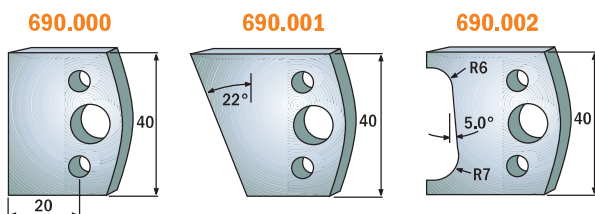

Profile knives cutting length=40mm (serie 690)

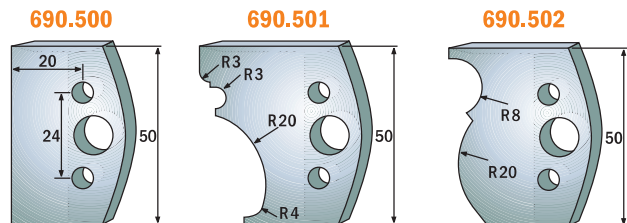

Profile knives cutting length=50mm (serie 690.5)

Adjustable Chamfering CNC Cutter



663.201



D mm	D_Max 45° mm	I mm	A	L mm	S mm	PACK QTY.	ORDER NO. Right-hand rotation
85	102	39,5	0°-45° - 0°+90°	92	20	1	663.201.11

Spare parts

790.395.12	39,5x12x1,5mm knife
663.999.01	38x6x12mm wedge
990.087.00	M6x8mm STEI screw (4x2mm threaded pin)
991.067.00	3mm hex key
663.999.02	Kit with 2 wedges and 1 screw for blocking rotation
990.099.00	M8x25mm TCEI screw
990.023.00	M8 (4mm) nut
991.081.00	4mm "T" hex key

TECHNICAL DETAILS: tool body in steel, two TC reversible knives in swiveling blade carriers. Cutting on periphery and both sides. Swiveling range towards top 0-45°, toward bottom 0-90°, infinitely variable adjustment according to precise scale. With positive stops at 7,5° through adjustment aide. No displacement of adjusted beveling angle when replacing blades. Right-hand rotation.

APPLICATION:

for jointing, rebating and chamfering of solid wood and wooden boards. Suitable for CNC router machines and stationary router machine with manual or mechanical feed.

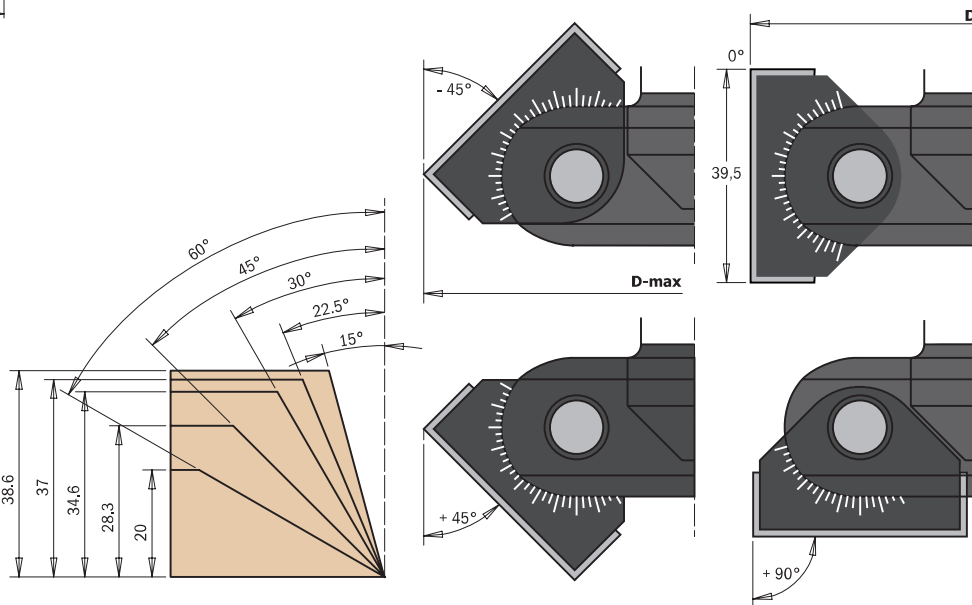

V-Groove - Folding - Signmaking CNC Router Cutters with Insert Knives



663.101



D mm	I mm	L mm	S mm	PACK QTY.	ORDER NO. Right-hand rotation
52	25	100	20	1	663.101.11

Spare parts

790.360.01	36x12x1,5mm knife
990.077.00	M3,5x7mm Torx screw
991.061.00	T15 Torx key

Optional

S790.360.03	36x12x1,5mm HW-SMG replaceable knife (4 cutting edges 35°)
-------------	--

TECHNICAL DETAILS:
 - Super Strength steel.
 - 1 cutting edges [Z1].

APPLICATION:

this innovative CNC router bit offers you an endless range of possibilities for V-Groove, miter folds, signmaking, lettering and chamfer edges. The tool mounts a high grade HWM reversible knife ideal for general purpose, chipboard and plywood, but a higher quality is available for laminated and MDF material.

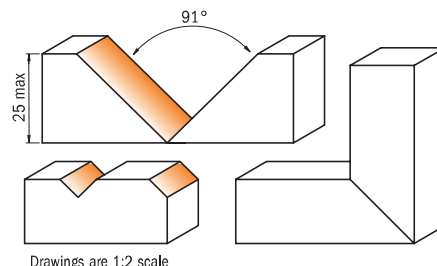

CORRECT KNIFE POSITIONING

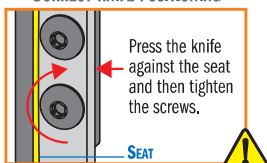

Complete Set for Decorating on MDF



616.000.01



This unique system includes a tool body with 22 profile knives designed for multiple applications on your CNC routers. Ideal for MDF, laminates, veneers, plastic, wood and solid surface materials.

TECHNICAL DETAILS:

Knives 20x20x2mm.

We recommend re-sharpening the knives on profile cutting edge.

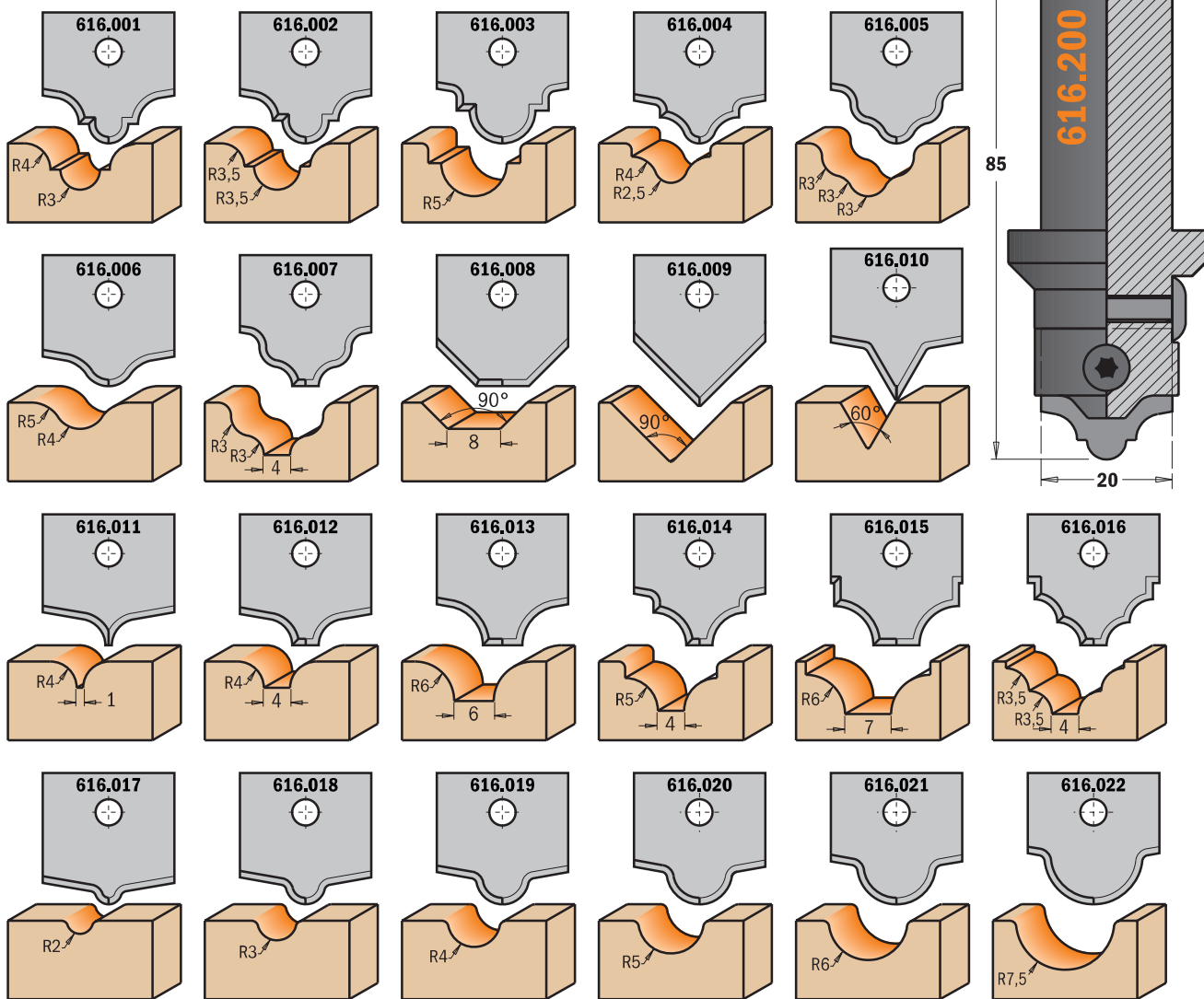

Drawings are 1:1 scale

DESCRIPTION	S mm	PACK QTY.	ORDER NO. Right-hand rotation	Spare parts		
Complete Set for Decorating on MDF	20	10	616.000.01			
Router cutter body with shank Ø20mm (insert knives not included)	20	10	616.200	616.200	990.077.00	991.061.00
Router cutter body with shank Ø12mm (insert knives not included)	12	10	616.120		990.077.00	991.061.00

REMARK: tool body and insert knives can be sold individually.

Complete Set for MDF Doors



615.004.01



Open some new doors with CMT. Our 4-piece set includes the most popular profile to make MDF panel doors for kitchens and bathrooms. Each bit is made from bar stock steel and is equipped with 5 different profile knives allowing enormous possibilities for easy and economical construction. The highest materials, the lowest tolerance in balancing and the precision in the sharpening of the knives let you obtain a smooth finish on your CNC machine.

- Spare parts**
- 991.061.00 T15 Tork key
 - 990.073.00 M3,5x5mm Torx screw
 - 990.075.00 M4x6mm Torx screw
 - 990.077.00 M3,5x7mm Torx screw

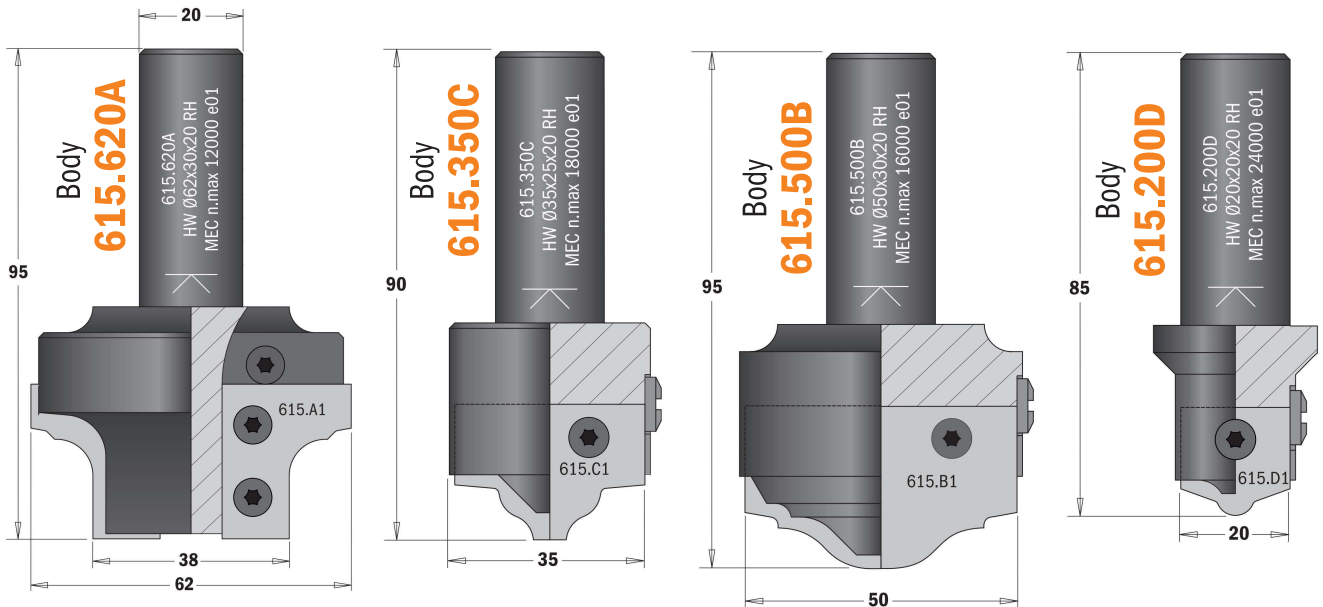

Standard Profile No. 1

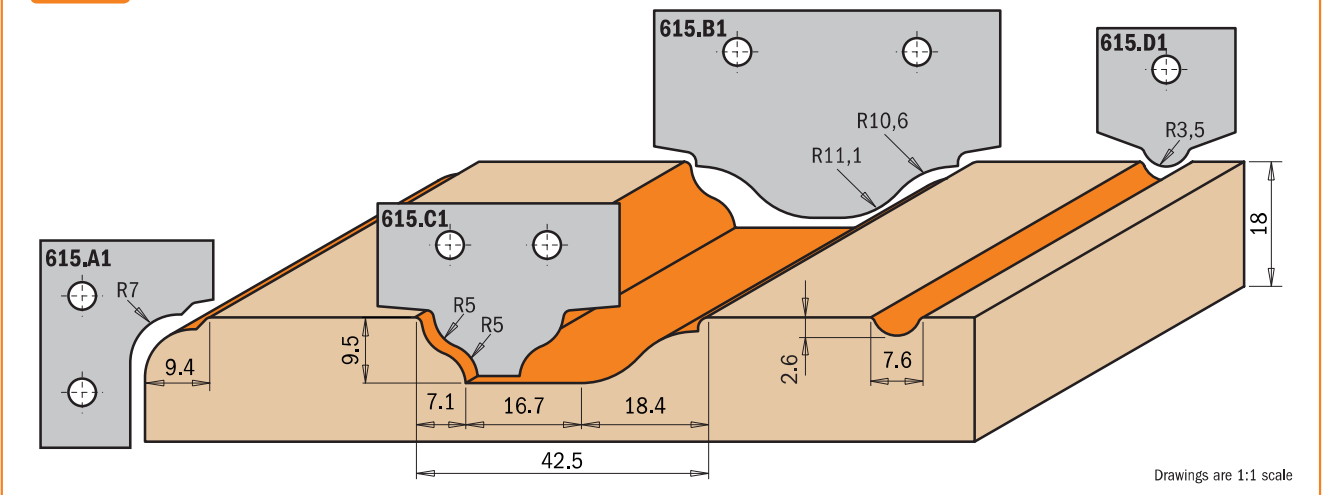

Drawings are 1:1 scale

DESCRIPTION	S mm	PACK QTY.	ORDER NO. Right-hand rotation
Complete Set for MDF Doors (Profile no. 1)	20	1	615.004.01

Optional

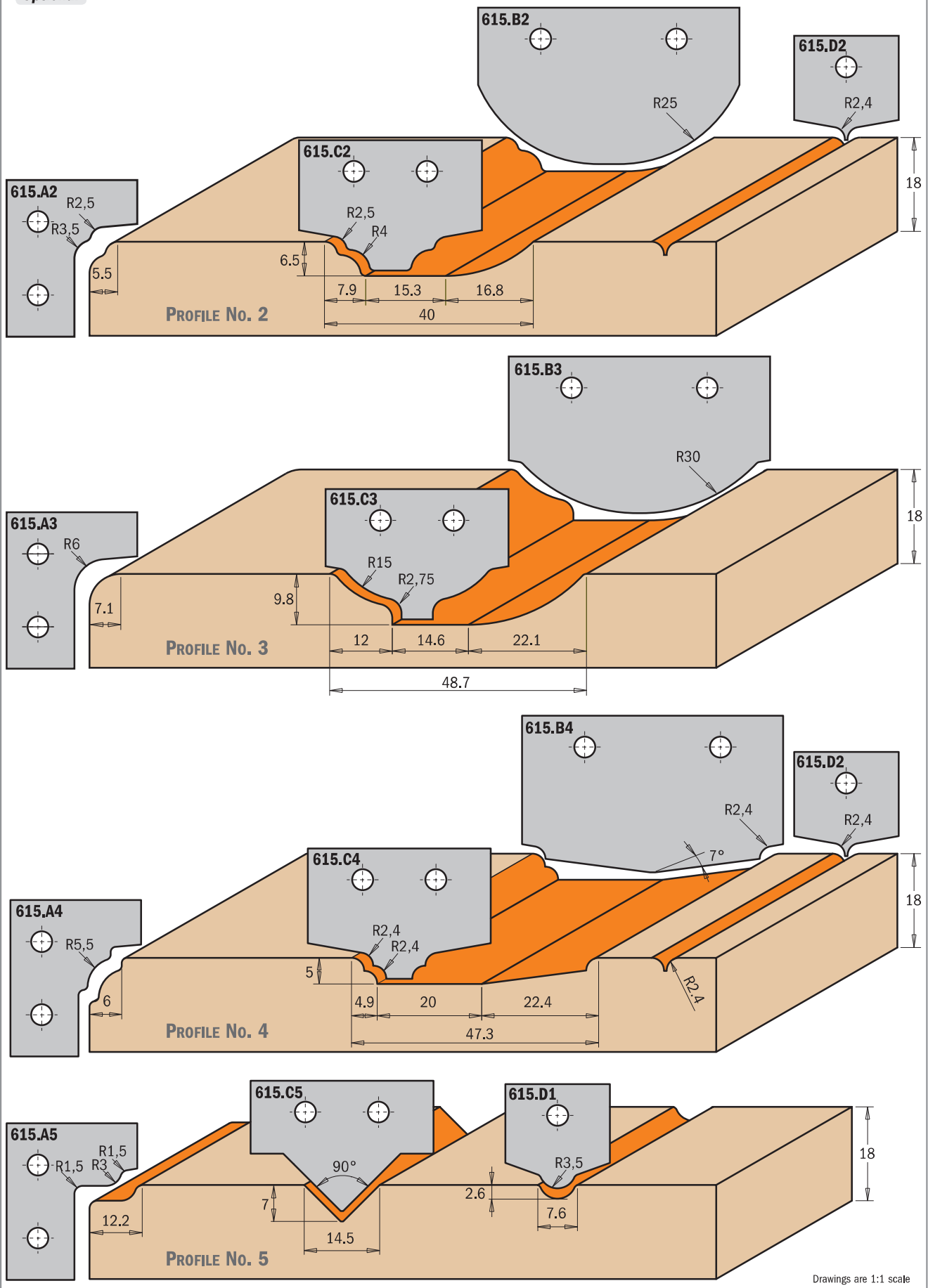

Drawings are 1:1 scale