

301

RH LH

B mm	D mm	S mm	PACK QTY.	ORDER NO. Right-hand rotation	ORDER NO. Left-hand rotation
8	16	M8	10	301.080.01	301.080.02
10	19,5	M8	10	301.000.01	301.000.02

FOR USE ON THE FOLLOWING MACHINES:
Nottmeyer (older models).

Spare parts



302

RH LH

B mm	D mm	S mm	PACK QTY.	ORDER NO. Right-hand rotation	ORDER NO. Left-hand rotation
8	16	M10	10	302.080.01	302.080.02
10	19,5	M10	10	302.000.01	302.000.02

FOR USE ON THE FOLLOWING MACHINES:
Ayen, Holzma, Knoevenagel, Mayer, Torwegge.

Spare parts



303

RH LH

B mm	D mm	S mm	PACK QTY.	ORDER NO. Right-hand rotation	ORDER NO. Left-hand rotation
8	16	M10/30°	10	303.080.01	303.080.02
10	19,5	M10/30°	10	303.000.01	303.000.02

FOR USE ON THE FOLLOWING MACHINES:
Alberti (older models).
Balestrini, Bilek, Busellato (older models).
Schleicher, Vitap (older models).

Spare parts



304

RH LH

B mm	D mm	S mm	PACK QTY.	ORDER NO. Right-hand rotation	ORDER NO. Left-hand rotation
8	16	M8/20° 48'	10	304.080.01	304.080.02
10	19,5	M8/20° 48'	10	304.000.01	304.000.02

FOR USE ON THE FOLLOWING MACHINES:
Balestrini, Bilek.

Spare parts



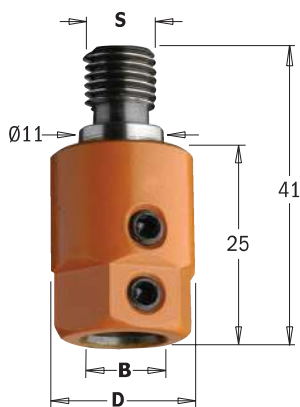

305

RH LH

B mm	D mm	S mm	PACK QTY.	ORDER NO. Right-hand rotation	ORDER NO. Left-hand rotation
8	16	M10/11	10	305.080.01	305.080.02
10	19,5	M10/11	10	305.000.01	305.000.02

FOR USE ON THE FOLLOWING MACHINES:
 Biesse (older models).
 Masterwood (Zangheri & Boschetti).
 Morbidelli, Torwegge, Vitap (new design).
 Weeke.

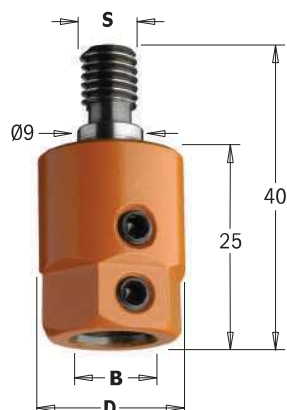
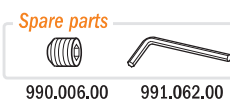

358

RH LH

B mm	D mm	S mm	PACK QTY.	ORDER NO. Right-hand rotation	ORDER NO. Left-hand rotation
8	16	M8/9	10	358.080.01	358.080.02
10	19,5	M8/9	10	358.000.01	358.000.02

FOR USE ON THE FOLLOWING MACHINES:
 Masterwood (Zangheri & Boschetti).
 Morbidelli, Nottmeyer (new design).

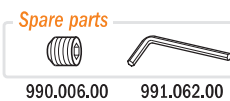

359

RH LH

B mm	D mm	S mm	PACK QTY.	ORDER NO. Right-hand rotation	ORDER NO. Left-hand rotation
10	19,5	M10	10	359.000.01	359.000.02

FOR USE ON THE FOLLOWING MACHINES:
 Scheer.

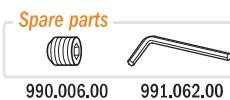

360.001

RH LH

B mm	d mm	D mm	PACK QTY.	ORDER NO. Right-hand rotation	ORDER NO. Left-hand rotation
10	20	15	10	360.001.01	360.001.02

FOR USE ON THE FOLLOWING MACHINES:
 For Biesse machines with quick drill change attachment.

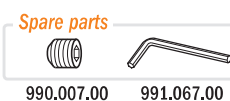



360.101

RH
LH

B mm	d mm	D mm	PACK QTY.	ORDER NO.
10	17,5	18	10	Right-hand & Left-hand rotation 360.101.00

FOR USE ON THE FOLLOWING MACHINES:
Vitap.



360.201

RH
LH

B mm	d mm	D mm	PACK QTY.	ORDER NO.
10	19,5	20	10	Right-hand & Left-hand rotation 360.201.00

FOR USE ON THE FOLLOWING MACHINES:
Morbidelli.



360.301

RH
LH

B mm	d mm	D mm	PACK QTY.	ORDER NO.
10	19,5	20	10	Right-hand & Left-hand rotation 360.301.00

FOR USE ON THE FOLLOWING MACHINES:
Masterwood, Maggi, Griggio.



360.401

RH
LH

B mm	d mm	D mm	PACK QTY.	ORDER NO.
10	20	17	10	Right-hand & Left-hand rotation 360.401.00

FOR USE ON THE FOLLOWING MACHINES:
Weeke.

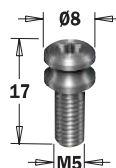
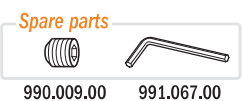

990.088

RH
LH

DESCRIPTION	PACK QTY.	ORDER NO.
Retaining screw for Weeke machines	10	Right-hand & Left-hand rotation 990.088.00

LINE	XTREME FLAT	XTREME	XTREME	INDUSTRIAL
PERFORMANCE	SUPERIOR ★★★★★	SUPERIOR ★★★★★	EXCELLENT ★★★★★	VERY GOOD ★★★
BIT				
DESCRIPTION	Designed for heavy duty drilling in Large-Scale Industrial Manufacturing ensuring high impact resistance and greater durability.	Designed for heavy duty drilling in Large-Scale Industrial Manufacturing ensuring high impact resistance and greater durability.	Designed for heavy-duty to medium-duty drilling in large-scale to medium-scale industrial manufacturing ensuring high impact resistance and greater durability.	Designed for medium-duty to light-duty drilling in medium-scale to small-scale industrial manufacturing ensuring rigorous impact resistance and good durability.
USER	LARGE-SCALE INDUSTRIAL MANUFACTURING	LARGE-SCALE INDUSTRIAL MANUFACTURING	LARGE-SCALE TO MEDIUM-SCALE INDUSTRIAL MANUFACTURING	MEDIUM-SCALE TO SMALL-SCALE INDUSTRIAL MANUFACTURING
RECOMMENDED USE	INDUSTRIAL PRODUCTION	INDUSTRIAL PRODUCTION	INDUSTRIAL/REMODELER	REMODELER
MATERIALS	Ideal for chipboard, MDF, HDF and laminates. Nonprotruding center-point and spurs make this tool perfect for low-thickness panels.	Ideal for chipboard, MDF, HDF and laminates.	Excellent for both hard and soft wood. Great for chipboard, MDF, HDF and laminates.	Excellent for both hard and soft wood. Good for chipboard, MDF, and laminates.
SHARPENING & MAINTENANCE	Flat edges with reinforced spurs allow perfect finishing and prolonged drilling. Xtreme Flat Sharpening	Specially designed reinforced spurs allow for impeccable finishing during operations involving high-speed cutting feed. Xtreme Sharpening	Specially designed reinforced spurs allow for impeccable finishing during operations involving high-speed cutting feed. Xtreme Sharpening	Standard design with negatively ground spurs providing good quality finishing without chipping. Negatively Ground Spurs
CARBIDE	INDUSTRIAL CHROMIUM MICROGRAIN CARBIDE The premium quality carbide produces clean bores with no rough edges and maintains a balanced center point. In addition to its safety features, Chromium Micrograin Carbide guarantees exceptional resistance to fatigue and abrasion and allows for an infinite number of resharpenings.	INDUSTRIAL CHROMIUM MICROGRAIN CARBIDE The special chromium enhanced carbide produces clean bores with no rough edges and maintains a balanced center point. In addition to its safety features, Chromium Micrograin Carbide guarantees exceptional resistance to fatigue and abrasion and allows for an infinite number of resharpenings.	INDUSTRIAL SINTERHIP HI-DENSITY CARBIDE The unique tip is made of high quality carbide enhanced via Sinterhip (hot isostatic pressing). This process guarantees long lasting performance and exceptionally clean bores.	INDUSTRIAL GRADE CARBIDE Fine and medium grain carbide grade guarantee reliable prolonged use.
COATING	 SOLID TUNGSTEN CARBIDE	 SOLID TUNGSTEN CARBIDE	C.M.T'S PTFE COATING provides a non-stick surface preventing resin, glue or sludge residue accumulation on the bit body. Baked at 420°, this unique industrial material is specifically designed to fit woodworking tool requirements.	C.M.T'S PTFE COATING provides a non-stick surface preventing resin, glue or sludge residue accumulation on the bit body. Baked at 420°, this unique industrial material is specifically designed to fit woodworking tool requirements.
PRICE RANGE	HIGH	HIGH	MEDIUM/HIGH	MEDIUM

Solid Carbide Dowel Drills

new

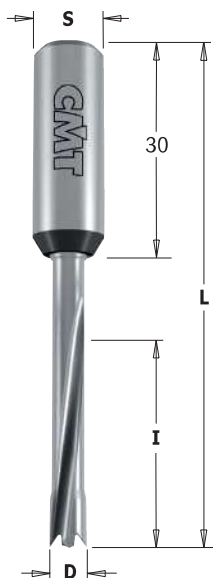

311.71/72

XTREME
FLAT SHARPENING



D mm	I mm	L mm	S mm	PACK QTY.	ORDER NO. Right-hand rotation	ORDER NO. Left-hand rotation
5	30	70	10x30	50	311.050.71	311.050.72
8	30	70	10x30	50	311.080.71	311.080.72

TECHNICAL DETAILS:

- Premium quality super strength steel for improved resistance and durability
- Premium quality HWM spiral portion
- 2 cutting edges [Z2] + 2 curved ground spurs [V2]
- 2 spiral flutes
- Parallel shank with driving flat and adjustable screw length
- Recommended feed speed 1+ 4m/minute -RPM 6000

APPLICATION:

ideal for use with chipboard, MDF, HDF and laminates.
Best for boring holes in low thickness panels – no center-point or spurs.
For use with chucks and boring adaptors on boring machines

Spare parts	Optional
 990.003.00	 990.088.00

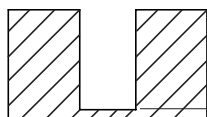

Flat sharpening with no center-point or spurs

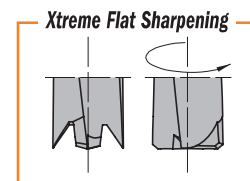

CMT's new high quality dowel drills guarantee excellent performance and extra-long life!

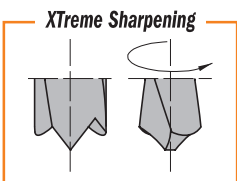
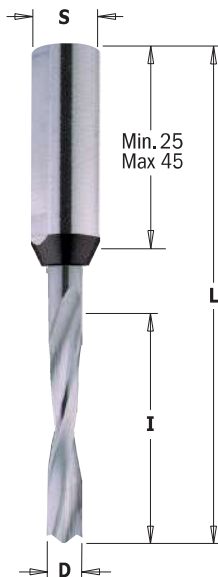
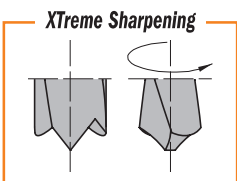
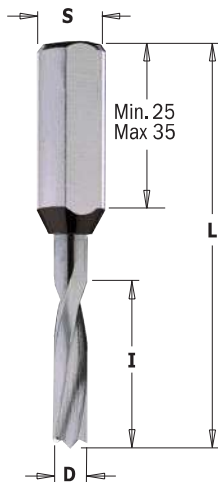

310.21/22 XTREME



D mm	I mm	L mm	S mm	PACK QTY.	ORDER NO. Right-hand rotation	ORDER NO. Left-hand rotation
1,3	5	57,5	10x30	50	310.013.20*	
2	12	57,5	10x27	50	310.020.21	310.020.22
3	9	57,5	10x35	50	310.530.21	310.530.22
3	18	57,5	10x25	50	310.030.21	310.030.22
4	20	57,5	10x25	50	310.040.21	310.040.22
5	22	57,5	10x27	50	310.050.21	310.050.22
6	22	57,5	10x27	50	310.060.21	310.060.22
6,35 (1/4")	22	57,5	10x27	50	310.064.21	310.064.22
8	22	57,5	10x25	50	310.080.21	310.080.22
10	22	57,5	10x25	50	310.100.21	310.100.22

* Boring bit for panel preboring.
Suitable for both right-hand and left-hand rotation.

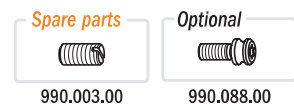

311.21/22 XTREME



D mm	I mm	L mm	S mm	PACK QTY.	ORDER NO. Right-hand rotation	ORDER NO. Left-hand rotation
1,3	5	70	10x45	50	311.013.20*	
2	12	70	10x40	50	311.020.21	311.020.22
3	18	70	10x40	50	311.030.21	311.030.22
4	27	70	10x28	50	311.040.21	311.040.22
5	30	70	10x28	50	311.050.21	311.050.22
6	30	70	10x27	50	311.060.21	311.060.22
6,35 (1/4")	30	70	10x30	50	311.064.21	311.064.22
8	35	70	10x25	50	311.080.21	311.080.22
10	35	70	10x25	50	311.100.21	311.100.22

* Boring bit for panel preboring.
Suitable for both right-hand and left-hand rotation.

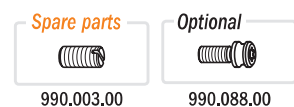

TECHNICAL DETAILS:

- Premium quality super-strength steel.
- HWM spiral portion with centre point.
- 2 cutting edges [Z2].
- 2 spiral flutes.
- 2 curved, negatively ground spurs [V2].
- Parallel shank with driving flat and adjustable screw length.

APPLICATION:

used on boring machines separately or with chucks for drilling blind holes in solid wood, wood composites, plastic and laminated materials.

Perfect for all materials and long-lasting performance!

Grinding Wheels for XTreme Sharpening



01.02

D mm	DESCRIPTION	DIMENSION mm	B mm	PACK QTY.	ORDER NO.
Ø3 a 7	Grinding wheel for resharpening	Ø125x5,5	Ø20	1	01.02.0316
Ø8 a 10	Grinding wheel for resharpening	Ø125x7	Ø20	1	01.02.0317

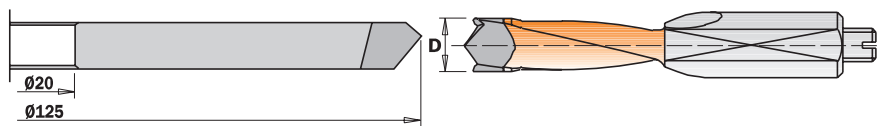

Solid Carbide Dowel Drills for Through Holes

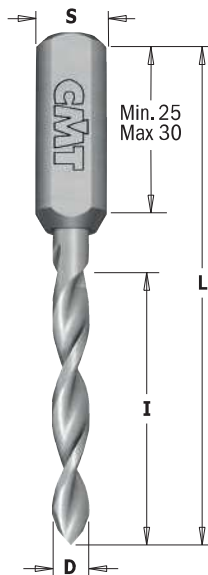

314.21/22 XTREME



D mm	I mm	L mm	S mm	PACK QTY.	ORDER NO. Right-hand rotation	ORDER NO. Left-hand rotation
3	27	70	10x30	50	314.030.21	314.030.22
4	35	70	10x26	50	314.040.21	314.040.22
5	35	70	10x26	50	314.050.21	314.050.22
6	35	70	10x26	50	314.060.21	314.060.22
8	35	70	10x26	50	314.080.21	314.080.22
10	35	70	10x27	50	314.100.21	314.100.22

For panels with maximum 20-30mm in thickness

TECHNICAL DETAILS:

- Premium quality super-strength steel.
- HWM spiral portion with centre point.
- 2 precision ground cutting edges [Z2].
- Double angle.
- 2 spiral flutes.
- Parallel shank with driving flat and adjustable screw length.

APPLICATION:

used on boring machines and dowel drilling devices.
Use for drilling through holes in solid wood, wood composites, plastic and laminated materials.

Spare parts	Optional
990.008.00	990.088.00

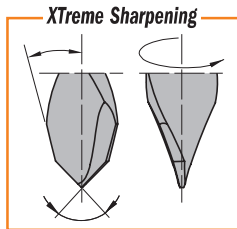

Solid Carbide Dowel Drills

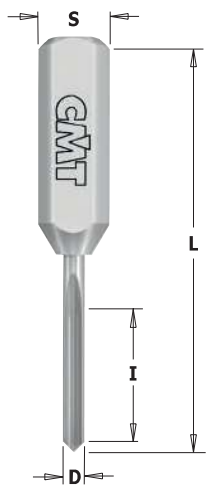

382 XTREME



D mm	I mm	L mm	S mm	PACK QTY.	ORDER NO. Right-hand & Left-hand rotation
2	12	57,5	10x30	50	382.2057
2	12	70	10x42,5	50	382.2070
2,5	16	57,5	10x24	50	382.2557
2,5	16	70	10x35	50	382.2570
3	15	57,5	10x26	50	382.3057
3	25	70	10x26	50	382.3070
3,5	18	57,5	10x24	50	382.3557
3,5	18	70	10x36	50	382.3570
5	25	57,5	10x25	50	382.5057
5	35	70	10x25	50	382.5070

TECHNICAL DETAILS:

- Premium quality HWM.
- Cutting head with precision balanced centre point.
- 1 cutting edge [Z1].
- Parallel shank with driving flat and length adjusting screw.

APPLICATION:

for drilling blind holes on solid wood, wood composites, plastic and laminated materials. For use on machining centres, point to point machines, CNC routers and hand-held routers equipped with chucks or adaptors.

Spare parts	Optional
990.003.00	990.088.00

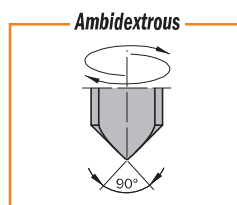

SECURITY TIPS:
These boring bits require more power compared to tradition dowel drills.
The number of boring bits to be used in a single drilling unit depends on the machine power.

Dowel Drills

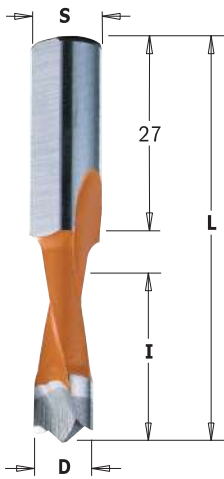

Xtreme Sharpening

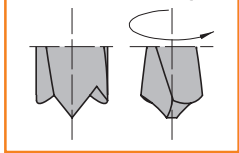

310.41/42 XTREME



D mm	I mm	L mm	S mm	PACK QTY.	ORDER NO. Right-hand rotation	ORDER NO. Left-hand rotation
5	27	57,5	10x27	50	310.050.41	310.050.42
6	27	57,5	10x27	50	310.060.41	310.060.42
7	27	57,5	10x27	50	310.070.41	310.070.42
8	27	57,5	10x27	50	310.080.41	310.080.42
9	27	57,5	10x27	50	310.090.41	310.090.42
10	27	57,5	10x27	50	310.100.41	310.100.42

TECHNICAL DETAILS:

- Premium quality super-strength steel.
- Spiral portion coated with orange or black P.T.F.E.
- Extra-fine micrograin carbide spiral portion with centre point.
- 2 cutting edges [Z2].
- 2 spiral flutes.
- 2 curved, negatively ground spurs [V2].
- Parallel shank with driving flat and adjustable screw length.

Spare parts

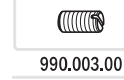

Optional



APPLICATION:

used on boring machines separately or with chucks for drilling blind holes in solid wood, wood composites, plastic and laminated materials.

Dowel Drills

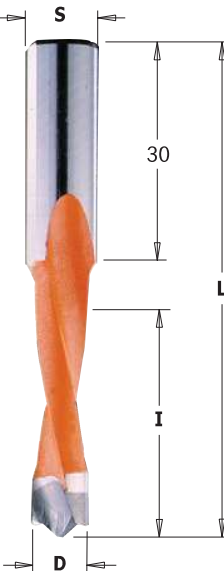

Xtreme Sharpening

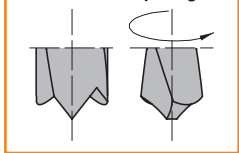

311.41/42 XTREME



D mm	I mm	L mm	S mm	PACK QTY.	ORDER NO. Right-hand rotation	ORDER NO. Left-hand rotation
5	35	70	10x30	50	311.050.41	311.050.42
6	35	70	10x30	50	311.060.41	311.060.42
7	35	70	10x30	50	311.070.41	311.070.42
8	35	70	10x30	50	311.080.41	311.080.42
9	35	70	10x30	50	311.090.41	311.090.42
10	35	70	10x30	50	311.100.41	311.100.42

TECHNICAL DETAILS:

- Premium quality super-strength steel.
- Spiral portion coated with orange or black P.T.F.E.
- Extra-fine micrograin carbide spiral portion with centre point.
- 2 cutting edges [Z2].
- 2 spiral flutes.
- 2 curved, negatively ground spurs [V2].
- Parallel shank with driving flat and adjustable screw length.

Spare parts

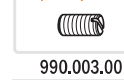

Optional



APPLICATION:

used on boring machines separately or with chucks for drilling blind holes in solid wood, wood composites, plastic and laminated materials.

Perfect for all materials and long-lasting performance!

CMT announces the new series of solid carbide boring bits, now available from their extensive industrial line. These bits are entirely made of premium quality super micrograin carbide from Ceratizit in Luxemburg.

The entire series offers several design features:

- the unique tip has curved, negatively ground spurs to produce exceptionally clear bores with no rough edges. Centre point balanced;
- the cylindrical head is bigger than traditional tips and is extremely resistant to prolonged use.

It lasts longer between sharpenings;

- the plunge edge runs all the way to the centre of the bit to reduce drilling resistance and increase production speed;
- the solid carbide construction guarantees an almost infinite number of resharpenings, and since it is a solid unit of carbide, it offers extra safety features;
- ideal for hardwood and difficult composites such as particle boards, MDF and veneered wood.
- excellent performance on high-speed boring units and CNC routers.

Dowel Drills for Through Holes

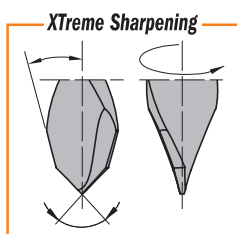
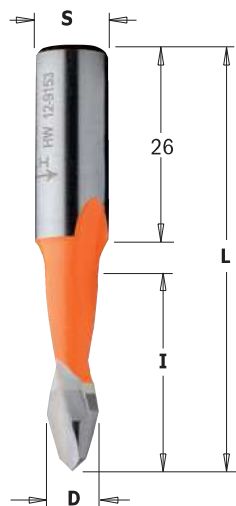

313.41/42

XTREME



D mm	I mm	L mm	S mm	PACK QTY.	ORDER NO. Right-hand rotation	ORDER NO. Left-hand rotation
5	27	57,5	10x26	50	313.050.41	313.050.42
8	27	57,5	10x26	50	313.080.41	313.080.42

For panels with maximum 20mm in thickness

TECHNICAL DETAILS:

- Super-strength steel.
- Spiral portion coated with orange or black P.T.F.E.
- Extra-fine micrograin carbide spiral portion with centre point.
- HW head with precision balanced centre point.
- 2 precision ground cutting edges [Z2].
- Double angle.
- 2 spiral flutes.
- Parallel shank with driving flat and length adjusting screw.

APPLICATION:

used on boring machines and dowel drilling devices. Use for drilling through holes in solid wood, wood composites, plastic and laminated materials.

Spare parts	Optional
990.003.00	990.088.00

Dowel Drills for Through Holes

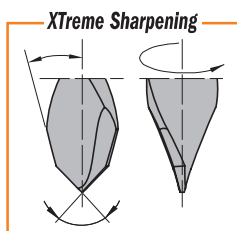
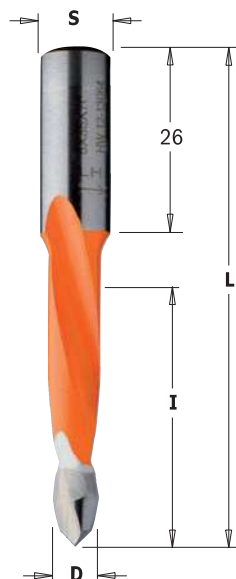

314.41/42

XTREME



D mm	I mm	L mm	S mm	PACK QTY.	ORDER NO. Right-hand rotation	ORDER NO. Left-hand rotation
5	35	70	10x26	50	314.050.41	314.050.42
6	35	70	10x26	50	314.060.41	314.060.42
7	35	70	10x26	50	314.070.41	314.070.42
8	35	70	10x26	50	314.080.41	314.080.42
10	35	70	10x26	50	314.100.41	314.100.42

For panels with maximum 30mm in thickness

TECHNICAL DETAILS:

- Super-strength steel.
- Spiral portion coated with orange or black P.T.F.E.
- Extra-fine micrograin carbide spiral portion with centre point.
- HW head with precision balanced centre point.
- 2 precision ground cutting edges [Z2].
- Double angle.
- 2 spiral flutes.
- Parallel shank with driving flat and length adjusting screw.

APPLICATION:

used on boring machines and dowel drilling devices. Use for drilling through holes in solid wood, wood composites, plastic and laminated materials.

Spare parts	Optional
990.003.00	990.088.00

Perfect for all materials and long-lasting performance!

CMT announces the new series of solid carbide boring bits, now available from their extensive industrial line. These bits are entirely made of premium quality super micrograin carbide from Ceratizit in Luxemburg.

The entire series offers several design features:

- the unique tip has curved, negatively ground spurs to produce exceptionally clear bores with no rough edges. Centre point balanced;
- the cylindrical head is bigger than traditional tips and is extremely resistant to prolonged use.

It lasts longer between sharpenings;

- the plunge edge runs all the way to the centre of the bit to reduce drilling resistance and increase production speed;
- the solid carbide construction guarantees an almost infinite number of resharpenings, and since it is a solid unit of carbide, it offers extra safety features;
- ideal for hardwood and difficult composites such as particle boards, MDF and veneered wood.
- excellent performance on high-speed boring units and CNC routers.



364

B mm	L mm	S mm	PACK Qty.	ORDER NO.
2	38	10x20	10	364.020.00
2,5	38	10x20	10	364.025.00
3	38	10x20	10	364.030.00
3,2	38	10x20	10	364.032.00
3,5	38	10x20	10	364.035.00
4	38	10x20	10	364.040.00
4,5	38	10x20	10	364.045.00
5	38	10x20	10	364.050.00

For use with the following items: 363 HWM

TECHNICAL DETAILS:

- Super-strength steel.
- Quick and secure assembly on twist drills.
- Precision relief.
- Parallel shank with driving flat.

APPLICATION:

for use with twist drills with common shank and bushing diameter. Used on boring machines equipped with adaptor chucks.

Spare parts



Bushings for Twist Drills



365

B mm	L mm	S mm	PACK Qty.	ORDER NO.
2	23	10	50	365.020.00
2,5	23	10	50	365.025.00
3	23	10	50	365.030.00
3,2	23	10	50	365.032.00
3,5	23	10	50	365.035.00
4	23	10	50	365.040.00
4,5	23	10	50	365.045.00
5	23	10	50	365.050.00
new 6	23	10	50	365.060.00

For use with the following items: 363 HWM

TECHNICAL DETAILS:

- Super-strength steel.
- Shank with driving flat.
- Axial cuttings for cylindrical drill clamps.

APPLICATION:

used with spiral boring bits with shank diameters equal to the bushing diameter. Used on boring machines equipped with adaptors.

Assembly Illustration



Solid Carbide Twist Drills "V" Point Sharpening



"V" Point
120°

363

HWM LONG LIFE Z2 RH LH

S=D mm	I mm	L mm	PACK QTY.	ORDER NO. Right-hand rotation	ORDER NO. Left-hand rotation
2	25	50	50	363.020.11	363.020.12
2,5	27	55	50	363.025.11	363.025.12
3	27	55	50	363.030.11	363.030.12
3,2	27	55	50	363.032.11	363.032.12
3,5	27	55	50	363.035.11	363.035.12
4	27	55	50	363.040.11	363.040.12
4,5	28	60	50	363.045.11	363.045.12
5	28	60	50	363.050.11	363.050.12

For use with the following items: 364-365

TECHNICAL DETAILS:

- Premium quality HWM.
- 2 precision ground cutting edges [Z2].
- 2 spiral flutes.
- Common shank and drilling diameter (S=D).

APPLICATION:

used in adaptor bushings.

Solid Carbide Twist Drills "V" Point 60° Sharpening

new

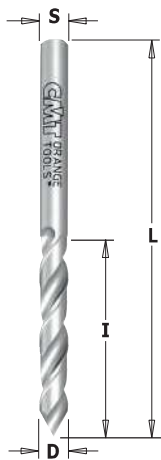

"V" Point
60°

363

HWM LONG LIFE Z2 RH LH

S=D mm	I mm	L mm	PACK QTY.	ORDER NO. Right-hand rotation	ORDER NO. Left-hand rotation
2,5	27	55	50	363.025.41	363.025.42
3	27	55	50	363.030.41	363.030.42
3,5	27	55	50	363.035.41	363.035.42
4	27	55	50	363.040.41	363.040.42

For use with the following items: 364-365

TECHNICAL DETAILS:

- Premium quality HWM.
- 2 precision ground cutting edges [Z2].
- 2 spiral flutes.
- Common shank and drilling diameter (S=D).

APPLICATION:

used in adaptor bushings.

Solid Carbide Twist Drills Negatively Ground Spurs Sharpening

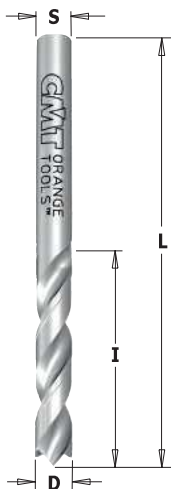

X-Treme
Sharpening

363

HWM LONG LIFE Z2 RH LH

S=D mm	I mm	L mm	PACK QTY.	ORDER NO. Right-hand rotation	ORDER NO. Left-hand rotation
2,5	27	55	50	363.025.21	363.025.22
3	27	55	50	363.030.21	363.030.22
4	27	55	50	363.040.21	363.040.22
5	28	60	50	363.050.21	363.050.22

For use with the following items: 364-365

TECHNICAL DETAILS:

- Premium quality HWM.
- 2 precision ground cutting edges [Z2].
- 2 spiral flutes.
- Common shank and drilling diameter (S=D).

APPLICATION:

used in adaptor bushings.

2 Flute Dowel Drills

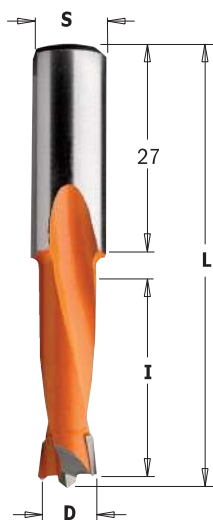

Negatively Ground Spurs

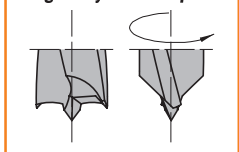

310



D mm	I mm	L mm	S mm	PACK QTY.	ORDER NO. Right-hand rotation	ORDER NO. Left-hand rotation
4	27	57,5	10x27	50	310.040.11	310.040.12
4,5	27	57,5	10x27	50	310.045.11	310.045.12
4,76	27	57,5	10x27	50	310.047.11	310.047.12
5	27	57,5	10x27	50	310.050.11	310.050.12
5,1	27	57,5	10x27	50	310.051.11	310.051.12
5,2	27	57,5	10x27	50	310.052.11	310.052.12
5,55	27	57,5	10x27	50	310.055.11	310.055.12
6	27	57,5	10x27	50	310.060.11	310.060.12
6,35	27	57,5	10x27	50	310.064.11	310.064.12
6,5	27	57,5	10x27	50	310.065.11	310.065.12
7	27	57,5	10x27	50	310.070.11	310.070.12
8	27	57,5	10x27	50	310.080.11	310.080.12
8,2	27	57,5	10x27	50	310.082.11	310.082.12
9	27	57,5	10x27	50	310.090.11	310.090.12
9,52	27	57,5	10x27	50	310.095.11	310.095.12
10	27	57,5	10x27	50	310.100.11	310.100.12
11	27	57,5	10x27	10	310.110.11	310.110.12
12	27	57,5	10x27	10	310.120.11	310.120.12
12,7	27	57,5	10x27	10	310.127.11	310.127.12
13	27	57,5	10x27	10	310.130.11	310.130.12
14	27	57,5	10x27	10	310.140.11	310.140.12
15	27	57,5	10x27	10	310.150.11	310.150.12
16	27	57,5	10x27	10	310.160.11	310.160.12

Spare parts



990.003.00

Optional



990.088.00

2 Flute Dowel Drills

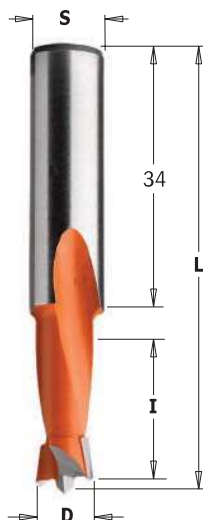

Negatively Ground Spurs

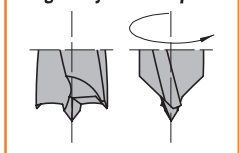

361



D mm	I mm	L mm	S mm	PACK QTY.	ORDER NO. Right-hand rotation	ORDER NO. Left-hand rotation
5	18	57,5	10x34	50	361.050.11	361.050.12
6	18	57,5	10x34	50	361.060.11	361.060.12
7	18	57,5	10x34	50	361.070.11	361.070.12
8	18	57,5	10x34	50	361.080.11	361.080.12
10	18	57,5	10x34	50	361.100.11	361.100.12

TECHNICAL DETAILS:

- Super-strength steel.
- Spiral portion coated with orange or black P.T.F.E.
- HW head with precision balanced centre point.
- 2 HW precision ground cutting edges [Z2].
- 2 negatively ground spurs [V2]
- 2 spiral flutes.
- Parallel shank with driving flat and length adjusting screw.

APPLICATION:

used on boring machines equipped with adaptors or chucks. Used to drill blind holes in solid wood, wood composites, plastic and laminated materials.

Spare parts



990.003.00

Optional



990.088.00

2 Flute Dowel Drills

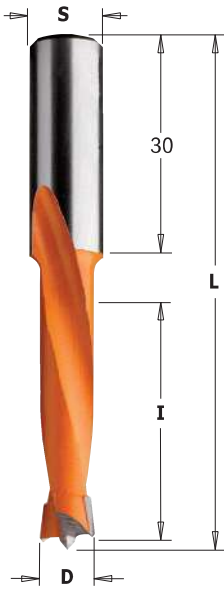

Negatively Ground Spurs

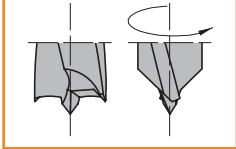

311



D mm	I mm	L mm	S mm	PACK QTY.	ORDER NO. Right-hand rotation	ORDER NO. Left-hand rotation
4	35	70	10x30	50	311.040.11	311.040.12
4,5	35	70	10x30	50	311.045.11	311.045.12
4,76	35	70	10x30	50	311.047.11	311.047.12
5	35	70	10x30	50	311.050.11	311.050.12
5,1	35	70	10x30	50	311.051.11	311.051.12
5,2	35	70	10x30	50	311.052.11	311.052.12
5,55	35	70	10x30	50	311.055.11	311.055.12
6	35	70	10x30	50	311.060.11	311.060.12
6,35	35	70	10x30	50	311.064.11	311.064.12
6,5	35	70	10x30	50	311.065.11	311.065.12
7	35	70	10x30	50	311.070.11	311.070.12
8	35	70	10x30	50	311.080.11	311.080.12
8,2	35	70	10x30	50	311.082.11	311.082.12
9	35	70	10x30	50	311.090.11	311.090.12
9,52	35	70	10x30	50	311.095.11	311.095.12
10	35	70	10x30	50	311.100.11	311.100.12
11	35	70	10x30	10	311.110.11	311.110.12
11,1	35	70	10x30	10	311.111.11	311.111.12
12	35	70	10x30	10	311.120.11	311.120.12
12,7	35	70	10x30	10	311.127.11	311.127.12
13	35	70	10x30	10	311.130.11	311.130.12
14	35	70	10x30	10	311.140.11	311.140.12
15	35	70	10x30	10	311.150.11	311.150.12
16	35	70	10x30	10	311.160.11	311.160.12

Spare parts



990.003.00

Optional



990.088.00

2 Flute Dowel Drills

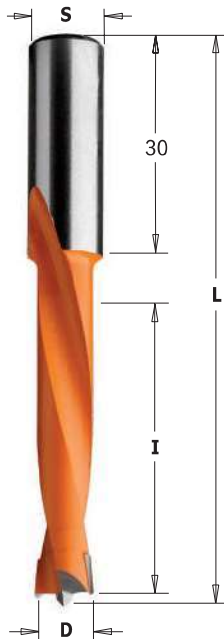

Negatively Ground Spurs

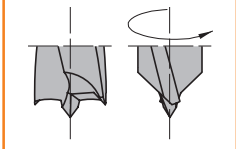

362



D mm	I mm	L mm	S mm	PACK QTY.	ORDER NO. Right-hand rotation	ORDER NO. Left-hand rotation
5	44	77	10x30	50	362.050.11	362.050.12
6	44	77	10x30	50	362.060.11	362.060.12
7	44	77	10x30	50	362.070.11	362.070.12
8	44	77	10x30	50	362.080.11	362.080.12
10	44	77	10x30	50	362.100.11	362.100.12
12	44	77	10x30	10	362.120.11	362.120.12

TECHNICAL DETAILS:

- Super-strength steel.
- Spiral portion coated with orange or black P.T.F.E.
- HW head with precision balanced centre point.
- 2 HW precision ground cutting edges [Z2].
- 2 negatively ground spurs [V2].
- 2 spiral flutes.
- Parallel shank with driving flat and length adjusting screw.

APPLICATION:

used on boring machines equipped with adaptors or chucks. Used to drill blind holes in solid wood, wood composites, plastic and laminated materials.

Spare parts



990.003.00

Optional



990.088.00

4 Flute Dowel Drills

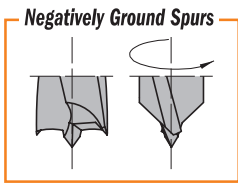
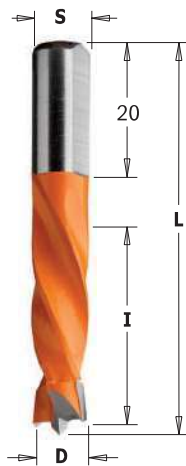

306



D mm	I mm	L mm	S mm	PACK QTY.	ORDER NO. Right-hand rotation	ORDER NO. Left-hand rotation
• 3	18	55,5	8x20	50	306.030.21	
5	30	55,5	8x20	50	306.050.11	306.050.12
5,55	30	55,5	8x20	50	306.055.11	306.055.12
6	30	55,5	8x20	50	306.060.11	306.060.12
6,35	30	55,5	8x20	50	306.064.11	306.064.12
7	30	55,5	8x20	50	306.070.11	306.070.12
8	30	55,5	8x20	50	306.080.11	306.080.12
9	30	55,5	8x20	50	306.090.11	306.090.12
10	30	55,5	8x20	50	306.100.11	306.100.12
12	30	55,5	8x20	50	306.120.11	306.120.12

• HWM

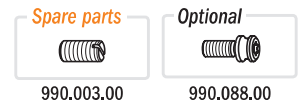

4 Flute Dowel Drills

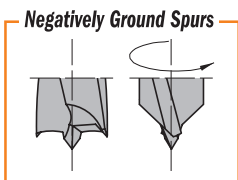
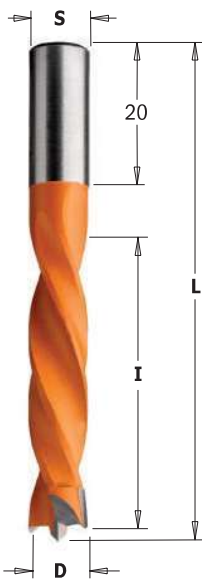

307



D mm	I mm	L mm	S mm	PACK QTY.	ORDER NO. Right-hand rotation	ORDER NO. Left-hand rotation
5	40	67	8x20	50	307.050.11	307.050.12
5,55	40	67	8x20	50	307.055.11	307.055.12
6	40	67	8x20	50	307.060.11	307.060.12
6,35	40	67	8x20	50	307.064.11	307.064.12
7	40	67	8x20	50	307.070.11	307.070.12
8	40	67	8x20	50	307.080.11	307.080.12
9	40	67	8x20	50	307.090.11	307.090.12
9,52	40	67	8x20	50	307.095.11	307.095.12
10	40	67	8x20	50	307.100.11	307.100.12
12	40	67	8x20	10	307.120.11	307.120.12

TECHNICAL DETAILS:

- Super-strength steel.
- Cutter portion coated with black or orange P.T.F.E.
- HW head with precision balanced centre point.
- 2 HW precision ground cutting edges [Z2].
- Negatively ground spurs [V2].
- 4 spiral flutes.
- Parallel shank with driving flat and length adjusting screw.

APPLICATION:

used on boring machines equipped with adaptors or chucks.
Used to drill blind holes in solid wood, wood composites, plastic and laminated materials.

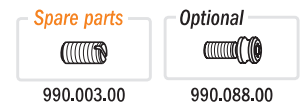

4 Flute Dowel Drills

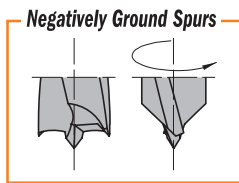
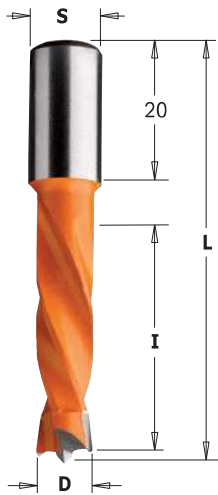

308



D mm	I mm	L mm	S mm	PACK Qty.	ORDER NO. Right-hand rotation	ORDER NO. Left-hand rotation
4	26	57,5	10x20	50	308.040.11	308.040.12
5	30	57,5	10x20	50	308.050.11	308.050.12
6	30	57,5	10x20	50	308.060.11	308.060.12
6,35	30	57,5	10x20	50	308.064.11	308.064.12
7	30	57,5	10x20	50	308.070.11	308.070.12
8	30	57,5	10x20	50	308.080.11	308.080.12
9	30	57,5	10x20	50	308.090.11	308.090.12
9,52	30	57,5	10x20	50	308.095.11	308.095.12
10	30	57,5	10x20	50	308.100.11	308.100.12
11	30	57,5	10x20	10	308.110.11	308.110.12
12	30	57,5	10x20	10	308.120.11	308.120.12
12,7	30	57,5	10x20	10	308.127.11	308.127.12
13	30	57,5	10x20	10	308.130.11	308.130.12
14	30	57,5	10x20	10	308.140.11	308.140.12
15	30	57,5	10x20	10	308.150.11	308.150.12
16	30	57,5	10x20	10	308.160.11	308.160.12

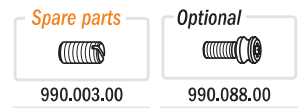

4 Flute Dowel Drills

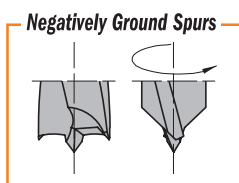
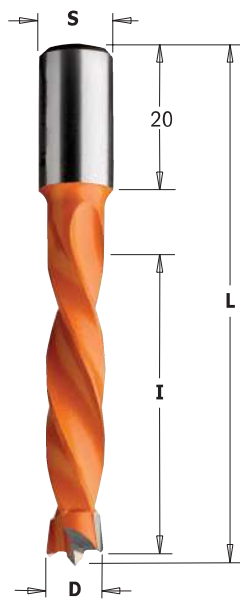

309



D mm	I mm	L mm	S mm	PACK Qty.	ORDER NO. Right-hand rotation	ORDER NO. Left-hand rotation
4	43	70	10x20	50	309.040.11	309.040.12
5	43	70	10x20	50	309.050.11	309.050.12
6	43	70	10x20	50	309.060.11	309.060.12
6,35	43	70	10x20	50	309.064.11	309.064.12
7	43	70	10x20	50	309.070.11	309.070.12
7,5	43	70	10x20	50	309.075.11	309.075.12
8	43	70	10x20	50	309.080.11	309.080.12
9	43	70	10x20	50	309.090.11	309.090.12
9,52	43	70	10x20	50	309.095.11	309.095.12
10	43	70	10x20	50	309.100.11	309.100.12
11	43	70	10x20	10	309.110.11	309.110.12
12	43	70	10x20	10	309.120.11	309.120.12
12,7	43	70	10x20	10	309.127.11	309.127.12
13	43	70	10x20	10	309.130.11	309.130.12
14	43	70	10x20	10	309.140.11	309.140.12
15	43	70	10x20	10	309.150.11	309.150.12
16	43	70	10x20	10	309.160.11	309.160.12

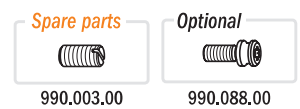

TECHNICAL DETAILS:

- Super-strength steel.
- Cutter portion coated with black or orange P.T.F.E.
- HW head with precision balanced centre point.
- 2 HW precision ground cutting edges [Z2].
- Negatively ground spurs [V2].
- 4 spiral flutes.
- Parallel shank with driving flat and length adjusting screw.

APPLICATION:

used on boring machines equipped with adaptors or chucks.
Used to drill blind holes in solid wood, wood composites, plastic and laminated materials.

4 Flute Dowel Drills

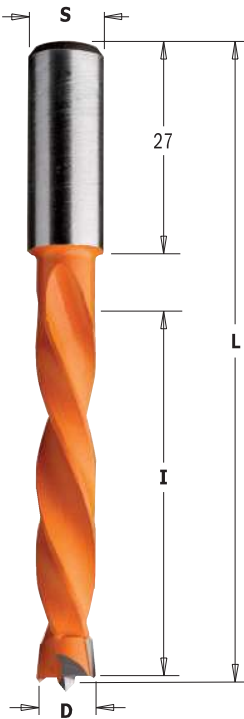

373

HW Z2 V2 RH LH

D mm	I mm	L mm	S mm	PACK Qty.	ORDER NO. Right-hand rotation	ORDER NO. Left-hand rotation
5	50	85	10x27	50	373.050.11	373.050.12
6	50	85	10x27	50	373.060.11	373.060.12
7	50	85	10x27	50	373.070.11	373.070.12
8	50	85	10x27	50	373.080.11	373.080.12
10	50	85	10x27	50	373.100.11	373.100.12
12	50	85	10x27	10	373.120.11	373.120.12

TECHNICAL DETAILS:

- Super-strength steel.
- Cutter portion coated with black or orange P.T.F.E.
- HW head with precision balanced centre point.
- 2 HW precision ground cutting edges [Z2].
- Negatively ground spurs [V2].
- 4 spiral flutes.
- Parallel shank with driving flat and length adjusting screw.

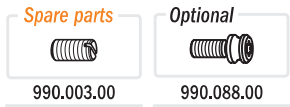

APPLICATION:

used on boring machines equipped with adaptors or chucks.
Used to drill blind holes in solid wood, wood composites, plastic and laminated materials.

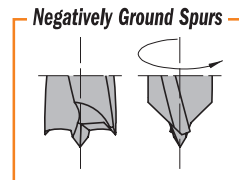

4 Flute Dowel Drills

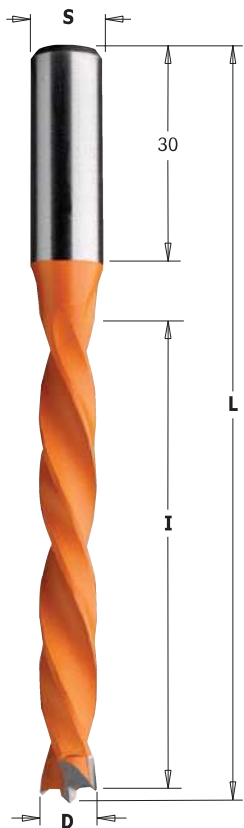

372

HW Z2 V2 RH LH

D mm	I mm	L mm	S mm	PACK Qty.	ORDER NO. Right-hand rotation	ORDER NO. Left-hand rotation
5	65	105	10x30	10	372.050.11	372.050.12
6	65	105	10x30	10	372.060.11	372.060.12
7	65	105	10x30	10	372.070.11	372.070.12
8	65	105	10x30	10	372.080.11	372.080.12
10	65	105	10x30	10	372.100.11	372.100.12
12	65	105	10x30	10	372.120.11	372.120.12

TECHNICAL DETAILS:

- Super-strength steel.
- Cutter portion coated with black or orange P.T.F.E.
- HW head with precision balanced centre point.
- 2 HW precision ground cutting edges [Z2].
- Negatively ground spurs [V2].
- 4 spiral flutes.
- Parallel shank with driving flat and length adjusting screw.



APPLICATION:

used on boring machines equipped with adaptors or chucks.
Used to drill blind holes in solid wood, wood composites, plastic and laminated materials.

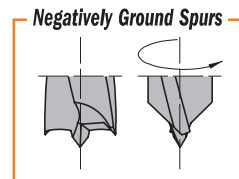

Dowel Drills with Countersink

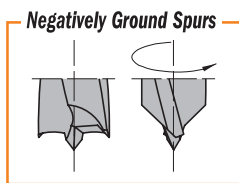
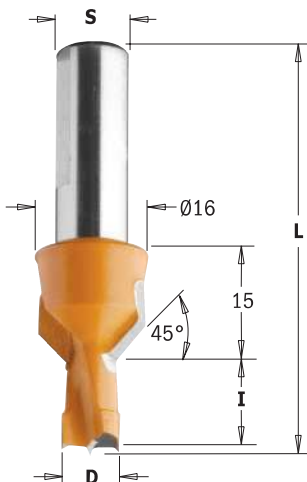

376-377

HW Z2 V2 RH LH

D mm	I mm	L mm	S mm	PACK QTY.	ORDER NO. Right-hand rotation	ORDER NO. Left-hand rotation
8	12	57,5	10	10	376.080.11	376.080.12
8	13	57,5	10	10	376.083.11	376.083.12
8	15	57,5	10	10	376.081.11	376.081.12
8	20	57,5	10	10	376.082.11	376.082.12
10	12	57,5	10	10	376.100.11	376.100.12
10	13	57,5	10	10	376.103.11	376.103.12
10	15	57,5	10	10	376.101.11	376.101.12
10	20	57,5	10	10	376.102.11	376.102.12
8	12	70	10	10	377.080.11	377.080.12
8	13	70	10	10	377.083.11	377.083.12
8	15	70	10	10	377.081.11	377.081.12
8	20	70	10	10	377.082.11	377.082.12
10	12	70	10	10	377.100.11	377.100.12
10	13	70	10	10	377.103.11	377.103.12
10	15	70	10	10	377.101.11	377.101.12
10	20	70	10	10	377.102.11	377.102.12

TECHNICAL DETAILS:

- Super-strength steel.
- Spiral portion coated with orange or black P.T.F.E.
- HW head with precision balanced centre point.
- 2 precision ground cutting edges [Z2].
- 2 ground spurs [V2].
- 2 spiral flutes.
- Parallel shank with driving flat and length adjusting screw.

Spare parts



990.003.00

Optional



990.088.00

APPLICATION:

used for drilling and countersinking in solid wood, wood composites, plastic and laminated materials. Suitable for high performance speed on boring machines equipped with adaptors or chucks.

Dowel Drills for Through Holes with Countersink

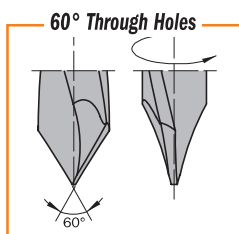
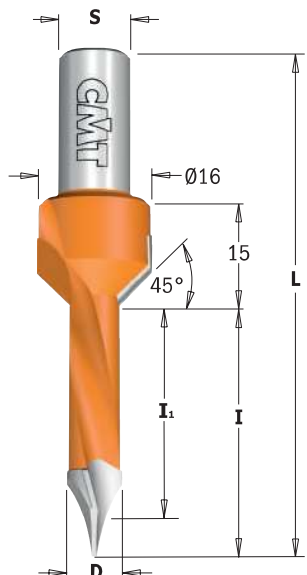

378

HW Z2 V2 RH LH

D mm	I mm	I ₁ mm	L mm	S mm	PACK QTY.	ORDER NO. Right-hand rotation	ORDER NO. Left-hand rotation
5	35	31	70	10	10	378.052.11	378.052.12
7	35	29,5	70	10	10	378.072.11	378.072.12
8	35	29	70	10	10	378.082.11	378.082.12
10	35	26,5	70	10	10	378.102.11	378.102.12

TECHNICAL DETAILS:

- Super-strength steel.
- Spiral portion coated with orange or black P.T.F.E.
- HW head with precision balanced centre point.
- 2 precision ground cutting edges [Z2].
- 2 ground spurs [V2].
- 2 spiral flutes.
- Parallel shank with driving flat and length adjusting screw.

Spare parts



990.003.00

Optional



990.088.00

APPLICATION:

used for drilling and countersinking in solid wood, wood composites, plastic and laminated materials. Suitable for high performance speed on boring machines equipped with adaptors or chucks.

2 Flute Dowel Drills for Through Holes

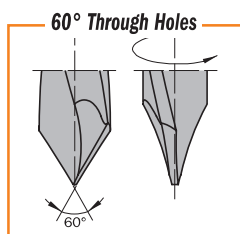
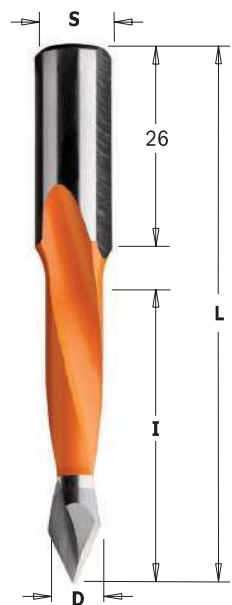
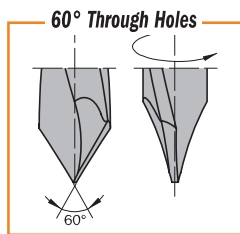
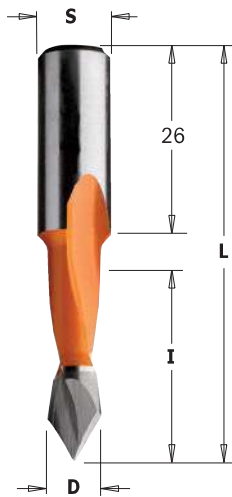

313



D mm	I mm	L mm	S mm	PACK QTY.	ORDER NO. Right-hand rotation	ORDER NO. Left-hand rotation
5	27	57,5	10x26	50	313.050.11	313.050.12
6	27	57,5	10x26	50	313.060.11	313.060.12
8	27	57,5	10x26	50	313.080.11	313.080.12
10	27	57,5	10x26	50	313.100.11	313.100.12

For panels with maximum 20mm in thickness.

TECHNICAL DETAILS:

- Super-strength steel.
- Spiral portion coated with orange or black P.T.F.E.
- HW head with precision balanced centre point.
- 2 precision ground cutting edges [Z2].
- 2 spiral flutes.
- Parallel shank with driving flat and length adjusting screw.

APPLICATION:

used on boring machines and dowel drilling devices.
Use for drilling through holes in solid wood, wood composites, plastic and laminated materials.

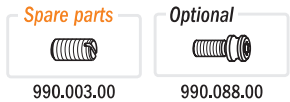

314



D mm	I mm	L mm	S mm	PACK QTY.	ORDER NO. Right-hand rotation	ORDER NO. Left-hand rotation
4	30	70	10x26	50	314.040.11	314.040.12
4,76	35	70	10x26	50	314.047.11	314.047.12
5	35	70	10x26	50	314.050.11	314.050.12
5,55	35	70	10x26	50	314.055.11	314.055.12
6	35	70	10x26	50	314.060.11	314.060.12
6,35	35	70	10x26	50	314.064.11	314.064.12
7	35	70	10x26	50	314.070.11	314.070.12
8	35	70	10x26	50	314.080.11	314.080.12
9	35	70	10x26	50	314.090.11	314.090.12
9,52	35	70	10x26	50	314.095.11	314.095.12
10	35	70	10x26	50	314.100.11	314.100.12
12	35	70	10x26	10	314.120.11	314.120.12
12,7	35	70	10x26	10	314.127.11	314.127.12

For panels with maximum 25-30mm in thickness.

366

D mm	I mm	L mm	S mm	PACK QTY.	ORDER NO. Right-hand rotation	ORDER NO. Left-hand rotation
5	44	77	10x26	50	366.050.11	366.050.12
6	44	77	10x26	50	366.060.11	366.060.12
8	44	77	10x26	50	366.080.11	366.080.12
10	44	77	10x26	50	366.100.11	366.100.12
12	44	77	10x26	10	366.120.11	366.120.12

For panels with maximum 30-40mm in thickness.

TECHNICAL DETAILS:

- Super-strength steel.
- Spiral portion coated with orange or black P.T.F.E.
- HW head with precision balanced centre point.
- 2 precision ground cutting edges [Z2].
- 2 spiral flutes.
- Parallel shank with driving flat and length adjusting screw.

APPLICATION:

used on boring machines and dowel drilling devices.
Use for drilling through holes in solid wood, wood composites, plastic and laminated materials.

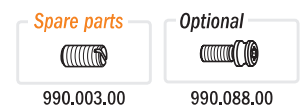

4 Flute Dowel Drills for Through Holes

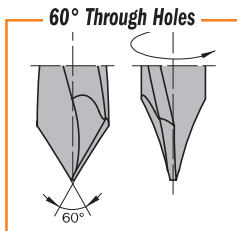
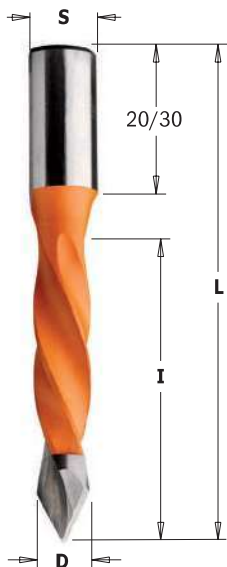

374 For panels with maximum 20-25mm in thickness.



D mm	I mm	L mm	S mm	PACK QTY.	ORDER NO. Right-hand rotation	ORDER NO. Left-hand rotation
5	30	57,5	10x20	50	374.050.11	374.050.12
8	30	57,5	10x20	50	374.080.11	374.080.12

375 For panels with maximum 30-35mm in thickness.

D mm	I mm	L mm	S mm	PACK QTY.	ORDER NO. Right-hand rotation	ORDER NO. Left-hand rotation
4	40	70	10x20	50	375.040.11	375.040.12
5	40	70	10x20	50	375.050.11	375.050.12
6	40	70	10x20	50	375.060.11	375.060.12
7	40	70	10x20	50	375.070.11	375.070.12
8	40	70	10x20	50	375.080.11	375.080.12
9	40	70	10x20	50	375.090.11	375.090.12
10	40	70	10x20	50	375.100.11	375.100.12

381 For panels with maximum 60-65mm in thickness.

D mm	I mm	L mm	S mm	PACK QTY.	ORDER NO. Right-hand rotation	ORDER NO. Left-hand rotation
5	70	115	10x30	10	381.050.11	381.050.12
6	70	115	10x30	10	381.060.11	381.060.12
8	70	115	10x30	10	381.080.11	381.080.12
10	70	115	10x30	10	381.100.11	381.100.12

TECHNICAL DETAILS:

- Super-strength steel
- Spiral portion coated with orange or black P.T.F.E.
- HW head with precision balanced centre point
- 2 precision ground cutting edges [Z2] - 4 spiral flutes
- Parallel shank with driving flat and length adjusting screw.

Spare parts



990.003.00

Optional



990.088.00

APPLICATION:

used on boring machines and dowel drilling devices.
Use for drilling through holes in solid wood, wood composites, plastic and laminated materials.

2 Flute Dowel Drills for Through Holes

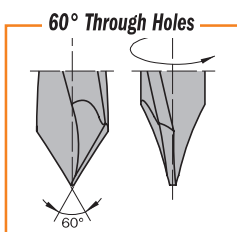
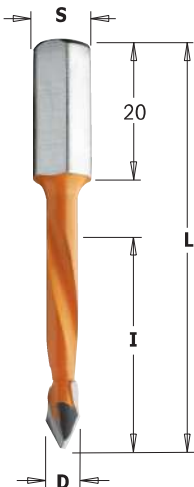

367



D mm	I mm	L mm	S mm	PACK QTY.	ORDER NO. Right-hand rotation	ORDER NO. Left-hand rotation
5	30	56	8x20	50	367.050.11	367.050.12
8	30	56	8x20	50	367.080.11	367.080.12

For panels with maximum 20-25mm in thickness.

368

D mm	I mm	L mm	S mm	PACK QTY.	ORDER NO. Right-hand rotation	ORDER NO. Left-hand rotation
5	43	70	8x20	50	368.050.11	368.050.12
6	43	70	8x20	50	368.060.11	368.060.12
7	43	70	8x20	50	368.070.11	368.070.12
8	43	70	8x20	50	368.080.11	368.080.12

For panels with maximum 35-40mm in thickness

TECHNICAL DETAILS:

- Super-strength steel
- Spiral portion coated with orange or black P.T.F.E.
- HW head with precision balanced centre point
- 2 precision ground cutting edges [Z2]
- 2 spiral flutes
- Parallel shank with driving flat and length adjusting screw.

Spare parts



990.003.00

Optional



990.088.00

APPLICATION:

used on boring machines and dowel drilling devices.
Use for drilling through holes in solid wood, wood composites, plastic and laminated materials.

Countersinks for 2 Flutes Dowel Drills

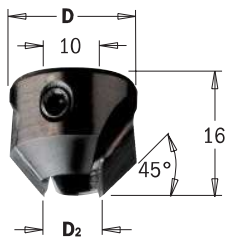

315



D ₂ mm	D mm	PACK QTY.	ORDER NO. Right-hand rotation	ORDER NO. Left-hand rotation
5 ~ 10	20	10	315.200.11	315.200.12
11 ~ 12	22	10	315.220.11	315.220.12

For assembly on the shank of the drill.
For use with the following parts: 310-311-362-313-314-366 HW



TECHNICAL DETAILS:

- Super-strength steel.
- 2 precision ground carbide tipped cutting edges [Z2].
- Direct clamp on the shank of the drills.

APPLICATION:

used for chamfering and drilling in solid wood, wood composites, plastic and laminated materials.

Countersinks for 4 Flutes Dowel Drills

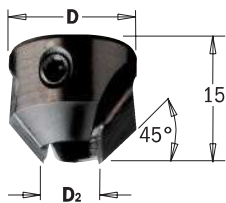

316



D ₂ mm	D mm	PACK QTY.	ORDER NO. Right-hand rotation	ORDER NO. Left-hand rotation
4	16	10	316.040.11	316.040.12
5	16	10	316.050.11	316.050.12
6	16	10	316.060.11	316.060.12
7	16	10	316.070.11	316.070.12
8	18	10	316.080.11	316.080.12
9	18	10	316.090.11	316.090.12
10	20	10	316.100.11	316.100.12
12	20	10	316.120.11	316.120.12

For assembly on the spiral head of the bit.
Adjustable depth.
For use with the following parts:
306-307-308-309-373-374-375-338-339
340-341-342-343-344-346-352-353 HW



TECHNICAL DETAILS:

- Super-strength steel.
- 2 HW precision ground cutting edges [Z2].

APPLICATION:

used for drilling and chamfering in solid wood, wood composites, plastic and laminated materials.

315 Assembly Illustration



316 Assembly Illustration

