

HSK Chucks for "ER40" Precision Collets



183.310

S	DESCRIPTION	TO BE USED WITH COLLET	PACK QTY.	ORDER NO. Right-hand rotation	ORDER NO. Left-hand rotation
HSK-F63	Clamping nut without bearing	ER40	1	183.310.01	183.310.02
HSK-F63	Clamping nut with bearing	ER40	1	183.310.11*	

* Suitable for right-hand and left-hand rotation.

For Homag, Eima, IMA from 9/94, Dubus, Weeke, Biesse, SCM, Morbidelli and Masterwood machines.



Non-Stick ORANGE CHROME™ SHIELD COATING

- prevents overheating
- protects against corrosion and rust
- reduces resin build-up
- longer life and greater tool performance

ISO30 Chucks for "ER40" Precision Collets



995.200

183.201

S	TO BE USED WITH COLLET	RETAINING STUD mm	PACK QTY.	ORDER NO. Right-hand rotation	ORDER NO. Left-hand rotation
ISO30	ER40	Ø12-8	1	183.201.01	

For Biesse machines



995.201

183.211

S	TO BE USED WITH COLLET	RETAINING STUD mm	PACK QTY.	ORDER NO. Right-hand rotation	ORDER NO. Left-hand rotation
ISO30	ER40	Ø13-9	1	183.211.01	

For Biesse machines with Omlat engine, Bulleri, Busellato, CMS and IMA machines.



995.202

183.221

S	TO BE USED WITH COLLET	RETAINING STUD mm	PACK QTY.	ORDER NO. Right-hand rotation	ORDER NO. Left-hand rotation
ISO30	ER40	Ø12,8-9	1	183.221.01	

For Alberti and Masterwood machines.



Clamping Nuts for Chucks with "ER40" Precision Collets



992.383

DESCRIPTION	PACK QTY.	ORDER NO. Right-hand rotation	ORDER NO. Left-hand rotation
Clamping nut without bearing For 183.201/211/221/310 chucks	1	992.383.01	992.383.02
Clamping nut with bearing For 183.201/211/221/310 chucks	1	992.383.11	



C-spanner for "ER40" Precision Collets



991.184

DESCRIPTION	PACK QTY.	ORDER NO.
C-Spanner for "ER40" precision collet	1	991.184.00

HSK Chuck for "ER32" Precision Collets

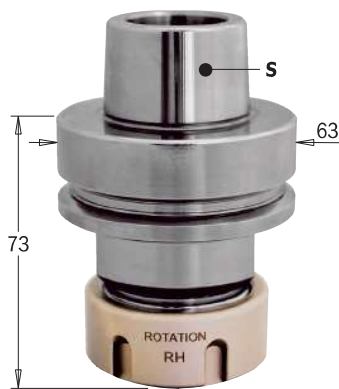

183.300

S	DESCRIPTION	TO BE USED WITH COLLET	PACK QTY.	ORDER NO. Right-hand rotation	ORDER NO. Left-hand rotation
HSK-F63	Clamping nut without bearing	ER32	1	183.300.01	183.300.02
HSK-F63	Clamping nut with bearing	ER32	1	183.300.11*	

* Suitable for right-hand and left-hand rotation.

For Homag, Eima from 9/94, Dubus, Weeke, Biesse, SCM, Morbidelli and Masterwood machines.



NON-STICK ORANGE CHROME™ SHIELD COATING

- prevents overheating
- protects against corrosion and rust
- reduces resin build-up
- longer life and greater tool performance

ISO30 Chucks for "ER32" Precision Collets

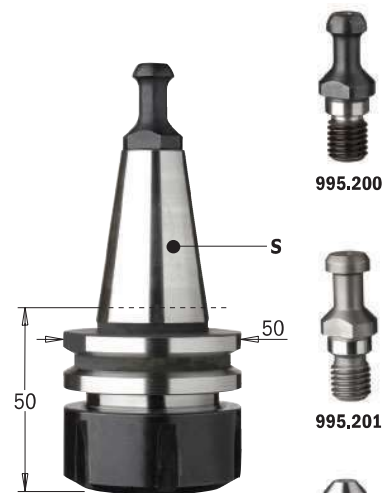

183.200

S	TO BE USED WITH COLLET	RETAINING STUD mm	PACK QTY.	ORDER NO. Right-hand rotation	ORDER NO. Left-hand rotation
ISO 30	ER32	Ø12-8	1	183.200.01	183.200.02

For Biesse machines.

183.210

S	TO BE USED WITH COLLET	RETAINING STUD mm	PACK QTY.	ORDER NO. Right-hand rotation	ORDER NO. Left-hand rotation
ISO 30	ER32	Ø13-9	1	183.210.01	183.210.02

For Biesse machines with Omlat engine, Bulleri, Busellato, CMS and IMA machines.

183.220

S	TO BE USED WITH COLLET	RETAINING STUD mm	PACK QTY.	ORDER NO. Right-hand rotation	ORDER NO. Left-hand rotation
ISO 30	ER32	Ø12,8-9	1	183.220.01	183.220.02

For Alberti and Masterwood machines.

ISO30 Chucks for "ER32" Precision Collets



183.250 without aluminium flange

S	TO BE USED WITH COLLET	RETAINING STUD mm	PACK QTY.	ORDER NO. Right-hand rotation	ORDER NO. Left-hand rotation
ISO 30	ER32	Ø8,5	1	183.250.01	183.250.02

For Morbidelli and SCM machines.

183.251 with Ø69,5mm aluminium flange fully assembled (*).

S	TO BE USED WITH COLLET	RETAINING STUD mm	PACK QTY.	ORDER NO. Right-hand rotation	ORDER NO. Left-hand rotation
ISO 30	ER32	Ø8,5	1	183.251.01	183.251.02

Spare parts 992.501.00 Ø69,5mm aluminium flange*

For Morbidelli and SCM machines.

Chucks for "ER32" Precision Collets

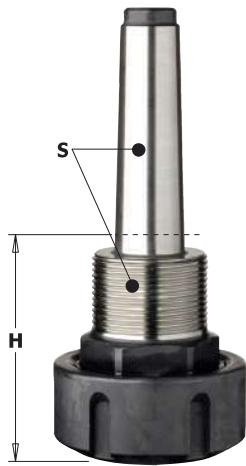

183.000/100

RH LH

S mm	TO BE USED WITH COLLET	H mm	PACK QTY.	ORDER NO. Right-hand rotation	ORDER NO. Left-hand rotation
MK2/M30x1,5	ER32	62	1	183.000.01	183.000.02
MK3/M30x1,5	ER32	70	1	183.100.01	

MK2/MK3 tapered shank

Chucks for "ER32" Precision Collets



995.400

183.400

RH

S mm	TO BE USED WITH COLLET	RETAINING STUD	PACK QTY.	ORDER NO. Right-hand rotation
Ø25x55	ER32	PS LEUCO	1	183.400.01

For machines with PS Leuco system.

Clamping Nuts for Chucks with "ER32" Collets



992.183

RH LH

DESCRIPTION	PACK QTY.	ORDER NO. Right-hand rotation	ORDER NO. Left-hand rotation
Clamping nut without bearing For 183.000/100/200/250/300/400 chucks	1	992.183.01	992.183.02
Clamping nut with bearing For 183.000/100/200/250/300/400 chucks	1	992.183.11	992.183.12

C-Spanner for "ER32" Precision Collets



991.183

DESCRIPTION	PACK QTY.	ORDER NO.
C-Spanner for "ER32" precision collets	1	991.183.00

HSK Chuck for "DIN6388" - EOC25 Precision Collet

RH

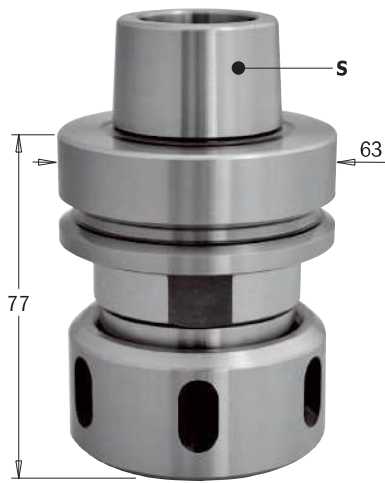

183.320

S	DESCRIPTION	TO BE USED WITH COLLET	PACK QTY.	ORDER NO. Right-hand rotation
HSK-F63	HSK chuck with bearing nut	EOC-25	1	183.320.01*

Spare parts 992.283.11 Clamping nut with bearing

* Suitable for left-hand rotation too.

For Homag, Eima from 9/94, Dubus, Weeke, Biesse, SCM, Morbidelli & Masterwood machines.

Clamping Nuts



992.283

RH

DESCRIPTION	PACK QTY.	ORDER NO. Right-hand rotation
Clamping nut without bearing	1	992.283.01
Clamping nut with bearing	1	992.283.11

For chuck 183.320.

C-Spanner for "DIN6388" & "ER40"



991.283

DESCRIPTION	PACK QTY.	ORDER NO.
C-Spanner for USAG 58-62-65	1	991.283.001

Precision Collets "DIN6388"



185 - EOC-25

mm	B inches	PACK QTY.	ORDER NO.	mm	B inches	PACK QTY.	ORDER NO.
3		10	185.030.00	13	1/2	10	185.130.00
4		10	185.040.00	14		10	185.140.00
5		10	185.050.00	16	5/8	10	185.160.00
6		10	185.060.00	18		10	185.180.00
8	5/16	10	185.080.00	20		10	185.200.00
10		10	185.100.00	25		10	185.250.00
12		10	185.120.00				

REMARK: special dimensions available on request.



185 - EOC-16

mm	B inches	PACK QTY.	ORDER NO.	mm	B inches	PACK QTY.	ORDER NO.
6		10	185.060.16	12		10	185.120.16
8	5/16	10	185.080.16	14		10	185.140.16
10		10	185.100.16	16	5/8	10	185.160.16

REMARK: special dimensions available on request.



184 - ER11

B mm	PACK QTY.	ORDER NO.
2	10	184.020.11
3	10	184.030.11
4	10	184.040.11
5	10	184.050.11
6	10	184.060.11

TECHNICAL DETAILS:

- replaceable Std "ER11" collets (from 1 to 7mm)
- fit most tapered spindle noses
- +0-0,7mm wide clamping tolerance
- suitable for most conical chucks.

REMARK: special dimensions available on request.



184 - ER16

B mm	PACK QTY.	ORDER NO.
2	10	184.020.16
3	10	184.030.16
4	10	184.040.16
5	10	184.050.16
6	10	184.060.16
7	10	184.070.16
8	10	184.080.16
9	10	184.090.16
10	10	184.100.16

TECHNICAL DETAILS:

- replaceable Std "ER16" collets (from 1 to 10mm)
- fit most tapered spindle noses
- +0-0,7mm wide clamping tolerance
- suitable for most conical chucks.

REMARK: special dimensions available on request.

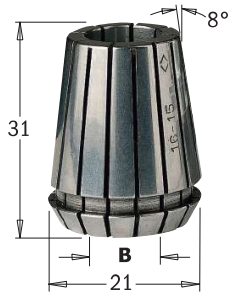

184 - ER20

B mm	PACK QTY.	ORDER NO.
2	10	184.020.20
3	10	184.030.20
4	10	184.040.20
5	10	184.050.20
6	10	184.060.20
6,35	10	184.064.20
7	10	184.070.20
8	10	184.080.20
9	10	184.090.20
10	10	184.100.20
11	10	184.110.20
12	10	184.120.20
12,7	10	184.127.20
13	10	184.130.20

TECHNICAL DETAILS:

- replaceable Std "ER20" collets (from 1 to 13mm)
- fit most tapered spindle noses
- +0-0,7mm wide clamping tolerance
- suitable for most conical chucks.

REMARK: special dimensions available on request.



184 - ER25

B mm	PACK QTY.	ORDER NO.
3	10	184.030.25
4	10	184.040.25
5	10	184.050.25
6	10	184.060.25
8	10	184.080.25
9	10	184.090.25
10	10	184.100.25
12	10	184.120.25
13	10	184.130.25
14	10	184.140.25
16	10	184.160.25

TECHNICAL DETAILS:

- replaceable Std "ER25" collets (from 1 to 16mm)
- fit most tapered spindle noses
- +0-0,7mm wide clamping tolerance
- suitable for most conical chucks.

REMARK: special dimensions available on request.



184 - ER32

B mm	PACK QTY.	ORDER NO.
3	10	184.030.00
4	10	184.040.00
5	10	184.050.00
6	10	184.060.00
6,35	10	184.065.00
7	10	184.070.00
8	10	184.080.00
9	10	184.090.00
9,52	10	184.095.00
10	10	184.100.00
11	10	184.110.00
12	10	184.120.00
13	10	184.130.00
14	10	184.140.00
15	10	184.150.00
16	10	184.160.00
17	10	184.170.00
18	10	184.180.00
19	10	184.190.00
20	10	184.200.00

For chucks
183.000/100/200/250/300/400

TECHNICAL DETAILS:

- replaceable Std "ER32" collets (from 3 to 20mm)
- fit most tapered spindle noses
- +0-0,7mm wide clamping tolerance
- suitable for most conical chucks.

REMARK: special dimensions available on request.



184 - ER40

B mm	PACK QTY.	ORDER NO.
3	10	184.032.00
4	10	184.042.00
5	10	184.052.00
6	10	184.062.00
6,35	10	184.064.00
7	10	184.072.00
8	10	184.082.00
9,52	10	184.096.00
10	10	184.102.00
12	10	184.122.00
13	10	184.132.00
14	10	184.142.00
16	10	184.162.00
18	10	184.182.00
19	10	184.192.00
20	10	184.202.00
25	10	184.252.00

For chucks
183.201/211/221/310

TECHNICAL DETAILS:

- replaceable Std "ER40" collets (from 3 to 25mm)
- fit most tapered spindle noses
- +0-0,7mm wide clamping tolerance
- suitable for most conical chucks.

REMARK: special dimensions available on request.

Cap Nuts for CNC Machines



993.0

RH LH

INTERNAL THREAD	PACK QTY.	ORDER NO. Right-hand rotation	ORDER NO. Left-hand rotation
Ø20x14Fx1"	1	993.020.01	993.020.02
M30x1,5	1	993.030.01	993.030.02

For machines with M33x3 threaded spindle nose.

ISO30 Retaining Studs



DESCRIPTION	D ₁ mm	D ₂ mm	ORDER NO.
Retaining stud for 183.200/201 "Biesse" chucks	8	12	995.200.00
Retaining stud for 183.210/211 "Biesse, Omlat, Bulleri, Busellato, Weeke and IMA" chucks	9	13	995.201.00
Retaining stud for 183.220/221 "Alberti-Masterwood" chucks	9	12,8	995.202.00
Retaining stud for 183.250/251 "SCM - Morbidelli" chucks	6,5	8,5	995.250.00
Retaining stud for "PS and Leuco" 183.400 chucks	M8		995.400.00

Cutter Arbor with HSK Tapered Shank

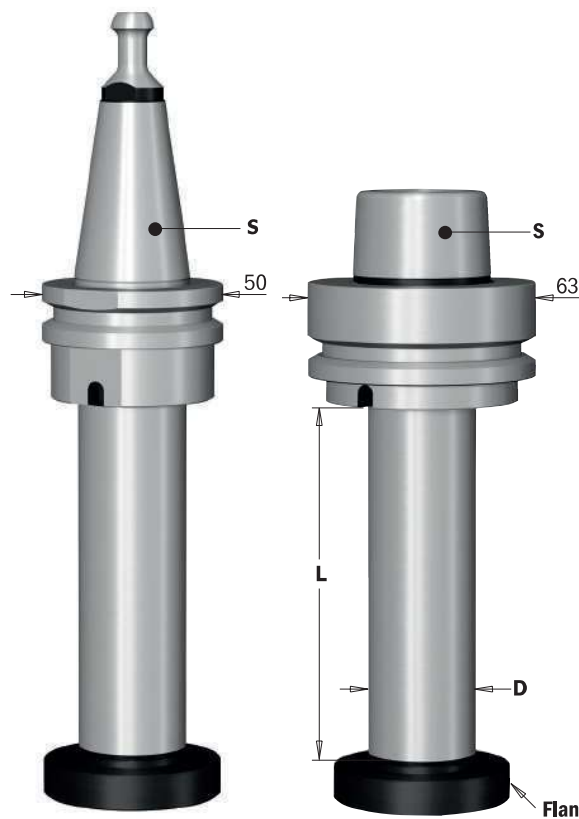

183.260

RH LH

S	DESCRIPTION	D x L mm	PACK QTY.	ORDER NO.
ISO30	Cutter arbor with ISO30 tapered shank	30x100	1	183.260.00

For Biesse machines.

REMARK: special dimensions available on request.

183.360

RH LH

S	DESCRIPTION	D x L mm	PACK QTY.	ORDER NO.
HSK-F63	Cutter arbor with HSK tapered shank	30x100	1	183.360.00
HSK-F63	Cutter arbor with HSK tapered shank	30x150	1	183.360.10
HSK-F63	Cutter arbor with HSK tapered shank	35x100	1	183.361.00
HSK-F63	Cutter arbor with HSK tapered shank	40x100	1	183.362.00

For Homag, Eima from 9/94, Dubus, Weeke, Biesse, SCM, Morbidelli and Masterwood machine.

Spare Parts for Chucks

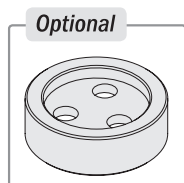
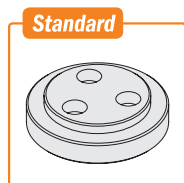

DESCRIPTION	ORDER NO.	DESCRIPTION	ORDER NO.
M6x25 TCEI screw	990.098.00	<i>Optional</i>	
Steel flange for with Ø30mm arbors - Male	992.560.30M	Steel flange for with Ø30mm arbors - Female	992.560.30F
Steel flange for with Ø35mm arbors - Male	992.560.35M	Steel flange for with Ø35mm arbors - Female	992.560.35F
Steel flange for with Ø40mm arbors - Male	992.560.40M	Steel flange for with Ø40mm arbors - Female	992.560.40F



183

DESCRIPTION	D mm	PACK QTY.	ORDER NO.
Universal assembly supports for chucks HSK-F63	63	1	183-HSK
Universal assembly supports for chucks ISO30	50	1	183-ISO

For HSK-F63 and ISO30 chucks

CMT now offers new universal assembly supports for HSK-F63 and ISO30 chucks. Thanks to the bi-directional roller bearings, which clamp the Left-hand rotation to the flange, the system offers the highest protection to the tool taper and clamps are no longer needed.

The special bidirectional roller bearing clamps the tool Left-hand rotation to the flange, offering the highest protection to the tool taper.

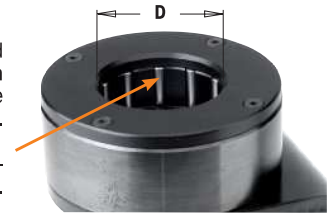

Saw Blade Arbor with Parallel Shank

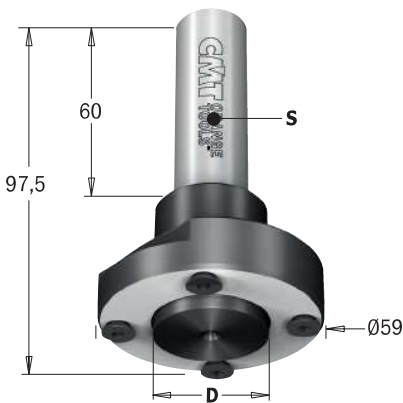

183.410



S mm	D mm	PIN HOLE	L mm	PACK QTY.	ORDER NO.
20	30	4/M6/48	97,5	1	183.410.30

Spare parts

990.083.00	M6x10mm TSPEI screw
991.067.00	3mm allen key
991.064.00	4mm allen key

Collet Chucks Clamp with MK2 Tapered Shank

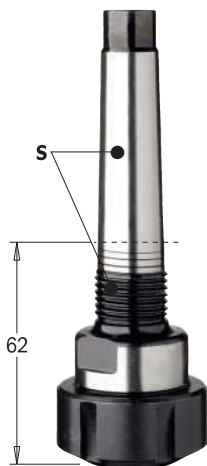

123



S	PACK QTY.	ORDER NO. Right-hand rotation	ORDER NO. Left-hand rotation
MK2/Ø20x14Fx1"	1	123.000.01	123.000.02

Spare parts

992.123.01	Clamping nut RH
992.123.02	Clamping nut LH
991.123.00	Type 45-50 c-spanner

Collets for 123 Chucks



124

D ₃ mm	PACK QTY.	ORDER NO.	D ₃ mm	PACK QTY.	ORDER NO.
6	1	124.060.00	10	1	124.100.00
6,35	1	124.064.00	12	1	124.120.00
8	1	124.080.00	12,7	1	124.127.00
9,5	1	124.095.00	14	1	124.140.00